



BULLETIN DE L'INSTITUT FRANÇAIS D'ARCHÉOLOGIE ORIENTALE

en ligne en ligne en ligne en ligne en ligne en ligne en ligne en ligne en ligne en ligne en ligne

BIFAO 120 (2020), p. 1-60

Sobhi Ashour, Magdi Ibrahim, Maher Bashendi, Laurent Coulon

The Tomb of Ta-Dḥwtj sꜣt Ḥr-tꜣ (Tathoutis daughter of Herta): Tomb 1 in the Necropolis of Bir el-Shaghala. The Architecture and the Paintings in the Antechamber

Conditions d'utilisation

L'utilisation du contenu de ce site est limitée à un usage personnel et non commercial. Toute autre utilisation du site et de son contenu est soumise à une autorisation préalable de l'éditeur (contact AT ifao.egnet.net). Le copyright est conservé par l'éditeur (Ifao).

Conditions of Use

You may use content in this website only for your personal, noncommercial use. Any further use of this website and its content is forbidden, unless you have obtained prior permission from the publisher (contact AT ifao.egnet.net). The copyright is retained by the publisher (Ifao).

Dernières publications

9782724711714	<i>La pensée et la pratique pharmacologiques d'Avicenne</i>	Sylvie Ayari
9782724711899	<i>BCAI 40</i>	
9782724711288	<i>Karnak-Nord XI</i>	Colin Hope
9782724711622	<i>BIFAO 126</i>	
9782724711059	<i>Les Inscriptions de visiteurs dans les Tombes thébaines</i>	Chloé Ragazzoli
9782724711455	<i>Les émotions dans l'Égypte Ancienne</i>	Rania Y. Merzeban (éd.), Marie-Lys Arnette (éd.), Dimitri Laboury, Cédric Larcher
9782724711639	<i>AnIsl 60</i>	
9782724711448	<i>Athribis XI</i>	Marcus Müller (éd.)

The Tomb of *Ta-Dḥwty s3t Ḥr-t3*
(Tathoutis daughter of Herta):
Tomb 1 in the Necropolis of Bir el-Shaghala*
The Architecture and the Paintings in the Antechamber

SOBHI ASHOUR, MAGDI IBRAHIM, MAHER BASHENDI
WITH AN ANNEX BY LAURENT COULON

ABSTRACT

Tomb 1 at Bir el-Shaghala (Dakhla Oasis) is a mausoleum-like structure belonging to *Ta-Dḥwty s3t Ḥr-t3* (Tathoutis daughter of Herta). The ground floor has an open-air court and an antechamber and two burial chambers with painted wall decoration. The upper floor has a chapel and a pyramid, which is the largest from a private tomb. The upper part witnessed two phases of use: two vaults were added inside the pyramid and two banqueting rooms to its north. The tomb's layout is modeled on late dynastic pyramidal tombs, but the vaulted rooms isolate it as a distinctive type.

The antechamber decoration shows many anomalies: the *ba* of Re, Tutu, and Horus Great of Strength all have human bodies. An apotheosis scene is unique in a tomb from Roman Egypt, as is the ceiling frieze of *ba*-birds and an Abydene fetish. The paintings in the rooms show stylistic affinities to the “Kharga Coffin Group” and attest to common motifs used in tombs and funerary objects in the oases. The tomb is datable to late 1st century CE on the basis of its architecture and paintings.

Keywords: Bir el-Shaghala, tombs in Greco-Roman times, Dakhla Oasis, pyramidal tombs, *Ta-Dḥwty s3t Ḥr-t3*, funerary practices in Roman Egypt, apotheosis of the deceased.

* The authors are grateful to Prof. Laila Azzam, Helwan University, and Dr. Maissara Hussein, Cairo University, for many enlightening discussions on the two aspects of the article. Our gratitude is addressed to the IFAO referees and to Prof. Colin Hope, Monash University, for his valuable remarks and for reading an earlier version of this article. The plans and drawings were made and copied *in situ* by Dr. Hani Hamed, Ministry of Tourism and Antiquities, Restoration Department, El-Minia Region, and rendered in Adobe Illustrator by Ahmed Tarek, Grand Egyptian Museum, except fig. 25, which was rendered by Walid el-Sayed, Sohag Archeological Inspectorate.

RÉSUMÉ

La tombe n° 1 de Bir el-Shaghala (oasis de Dakhla) est une sépulture de type mausolée appartenant à *Ta-Dḥwtj s3t Hr-t3* (Tathoutis fille de Herta). Le rez-de-chaussée comprend une cour en plein air et une antichambre ainsi que deux chambres funéraires avec des décorations murales peintes. Le niveau supérieur comprend une chapelle et une pyramide, laquelle est la plus grande connue à ce jour pour une tombe privée. La partie supérieure a connu deux phases d'utilisation : deux voûtes ont été ajoutées à l'intérieur de la pyramide et deux salles de banquet ont été aménagées au nord de celle-ci. La disposition de la tombe est calquée sur celle des tombes à structure pyramidale de l'époque tardive, mais les salles voûtées en font un type à part.

La décoration de l'antichambre présente de nombreuses anomalies : les *ba-s* de Rê, Toutou et Horus-Grand-de-Force sont tous anthropomorphes. On y trouve une scène de divinisation unique pour une tombe égyptienne d'époque romaine, ainsi qu'une frise de *ba-s* et un fétiche abydnien sans parallèles connus. Les peintures des salles montrent des affinités stylistiques avec le « groupe des cercueils de Kharga » et attestent de motifs communs utilisés dans les tombes et le mobilier funéraire des oasis. La tombe peut être datée de la fin du 1^{er} siècle apr. J.-C. grâce à son architecture et ses peintures.

Mots-clés : Bir el-Shaghala, tombes d'époque gréco-romaine, Dakhla Oasis, tombe à structure pyramidale, *Ta-Dḥwtj s3t Hr-t3*, pratiques funéraires à l'époque romaine, divinisation du défunt.



THE NECROPOLIS of Bir el-Shaghala, located 3 km northwest of Mut, the modern capital of Dakhla Oasis, is one of the necropoleis of Mothis, the ancient capital of the Oasis. Excavations by the Egyptian Supreme Council of Antiquities at the site started in 2002 and the work is ongoing. The team was headed by Maher Bashendi until 2015 and is currently directed by Magdi Ibrahim. The tombs show specific characteristics of architecture and layout that isolate them as a distinctive type. This type includes a ground floor with multi-chambered funerary units preceded by an open-air court, in addition to an upper storey consisting of a pyramid with a funerary chapel in front of it. The decoration of Tomb 1, like other tombs at the site, shows a traditional Egyptian decorative program. In Gael Cartron's catalogue, Tomb 1 was erroneously attributed to the regional governor Ankh Wasset Neb, perhaps owing to very preliminary and imprecise reports.¹ This article is devoted to the study of the tomb architecture, which seems to have more than one phase, in addition to the paintings in the antechamber. A study of the decoration of the two funerary chambers and the finds from Tomb 1 will be the subjects of a series of articles, hopefully to be published in sequence.

¹ CARTRON 2012, II, p. 73, depended on a report in the *BIA* 30, 2004, pp. 119-120, quoting an article by Samar Ezzat in the *Egyptian Gazette*, 11 November 2004.

1. THE ARCHITECTURE OF THE TOMB

[FIG. 1]

The tomb is accessible from the east via a staircase of six steps, 137 cm in width, leading into a rectangular open-air court; both the staircase and the walls of the court are built in mud brick and coated with a thick layer of lime plaster (fig. 2). The third step of the staircase was perhaps flanked by two jambs; the one on the left side is better preserved, and is likely the remains of a broken lintel. Another broken lintel terminates the outermost entrance and marks the extension of the open court near the neighboring Tomb 3. Two tiny benches run the length of this forecourt, the floor of which was paved with slabs of sandstone. On the right is the upper part of a rectangular sandstone horned altar 68 × 68 cm (fig. 3). Its lateral position in the entrance is paralleled by other altars in the necropolis,² and may be due to the lack of space.

The Egyptian style entrance to the tomb is built from sandstone blocks, surmounted by a cavetto cornice, measuring 137 cm in height, 77 cm in width and 104 cm in depth. The door was closed by a portcullis slab that slid inside a socket measuring 88 × 43 cm, penetrating the east wall above the entrance. A portion of the slab was still in the socket when the tomb was excavated in 2002, according to an earlier photographic record. The remaining portion of the portcullis slab shows a god seated on a block throne with traces of a scepter and a female figure with a scepter behind him (fig. 4). The relief is similar to the relief on decorated slabs from a temple in Mut el-Kharab from the reign of Psamtik I.³ The portcullis closing technique is well-attested in Dakhla Oasis necropoleis such as Kellis,⁴ and Bir el-Arab 3,⁵ but another example from Terenouthis, dated to the Roman era,⁶ indicates a Lower Egyptian use. The tradition is well known in both royal and private tombs of the Old Kingdom.⁷

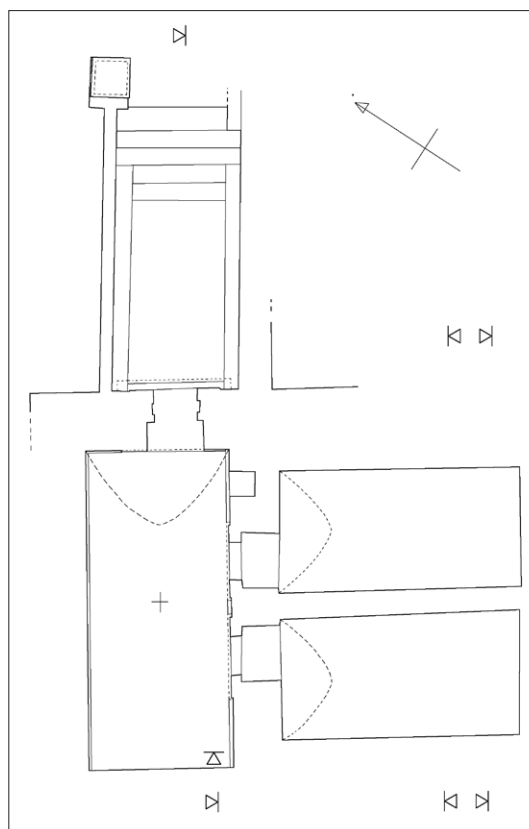

FIG. 1: Bir el-Shaghala Tomb 1, ground floor, plan.

² It is possible that the altar was placed laterally to the entrance to give more space for movement into and in front of the tomb, because the stair width is only 1.37 m. Similarly placed altars in the courts of other Bir el-Shaghala tombs are attested in Tombs 2 and 6, with their altars located inside *arcosolia*; see BASHENDI 2013, figs 8-9; IBRAHIM, ASHOUR 2020, pl. 16, 18, respectively.

³ KAPER 2001, 71-78, pl. 23; our gratitude to Colin Hope for this reference and his remark on a similar block from this monument found at Bir el-Shaghala many years ago by the Dakhla Oasis Project.

⁴ HOPE, MCKENZIE 1999, pl. 4.

⁵ YAMANI forthcoming.

⁶ BADAWY 1957, pp. 52-54.

⁷ BIRRELL 2000, pp. 13-28, esp. p. 25, fig. 5.



FIG. 2: Bir el-Shaghala Tomb 1, open court with the entrance and altar.

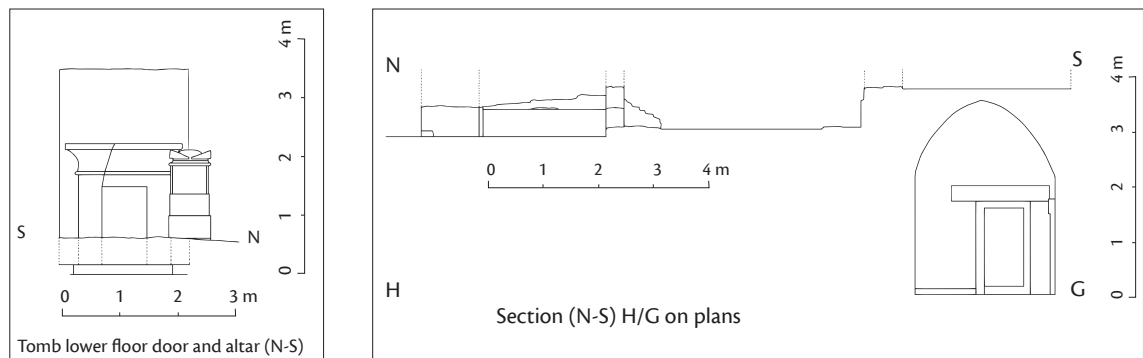

FIG. 3: Bir el-Shaghala Tomb 1, elevation of the entrance with the altar on the right.

The door leads into a spacious vaulted antechamber, built in mud brick and coated with lime plaster, measuring 5.60 m from east to west; its width from north to south is 2.54 m on the eastern wall and 2.58 m on the western wall (figs 5, 6). The maximum height of the restored ceiling is 3.53 m. The lower portion of the southern wall, which is the front wall of the two funerary chambers, is built from sandstone blocks. The earlier photographic record shows sandstone blocks above the two entrances, perhaps once belonging to an Egyptian cavetto cornice, comparable to similar entrances in other tombs (Tombs 2, 5 and 6, for example).⁸ On the southern wall, just to the left of the door to the eastern funerary chamber, there is a niche cut in the wall measuring 61 × 44 × 44 cm (*infra*, fig. 29) that is likely to be an original feature of the antechamber, because the paintings around its four edges respect its previous existence.

The two entrances to the two funerary chambers measure 133 × 68 cm each, with two much larger lintels each measuring 146 × 27 cm, both decorated with winged solar discs (fig. 6). These two funerary rooms with vaulted ceilings are constructed from sandstone blocks, but their walls do not have identical measurements. Both long walls in the western room measure 4.22 m, but the width of the entrance wall is 2.16 m, while the width of the rear wall is 2.20 m. The right-hand wall of the eastern room measures 4.28 m in length, and the left-hand wall is 4.27 m long. The width of the entrance wall is 2.13 m, and the width of the rear wall is 2.12 m (fig. 7). Both rooms are 2.16 m high (figs 1, 5). A thick filling of mortar was used in the ceiling; it is still visible in the holes made by robbers.⁹ The walls of both funerary



FIG. 4: Bir el-Shaghala Tomb 1, lower portion of the portcullis slab.

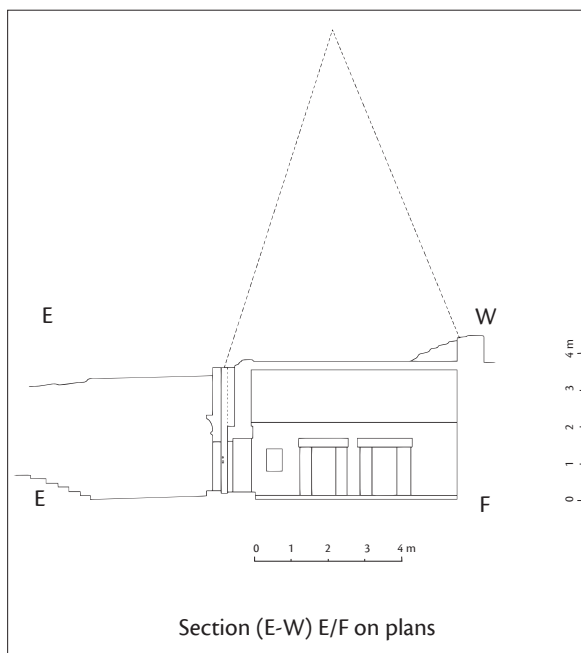

FIG. 5: Bir el-Shaghala Tomb 1, east-west section of ground floor, with the pyramid restored.

⁸ BASHENDI 2013, figs II-12; IBRAHIM, ASHOUR 2020, pl. 10, 14.

⁹ The Late Period and Roman necropolis in Oxyrhynchus has similar openings in the ceiling caused by robbers; see PADRÓ 2007, p. 130. BIRRELL 2000, pp. 13–28, noticed that robbers in antiquity were successful in penetrating the ceiling just above the funerary unit in Old Kingdom tombs.



FIG. 6: Bir el-Shaghala Tomb 1, antechamber: entrances to the funerary chambers.



FIG. 7: Bir el-Shaghala Tomb 1, ground floor: view into the eastern funerary chamber from the antechamber.

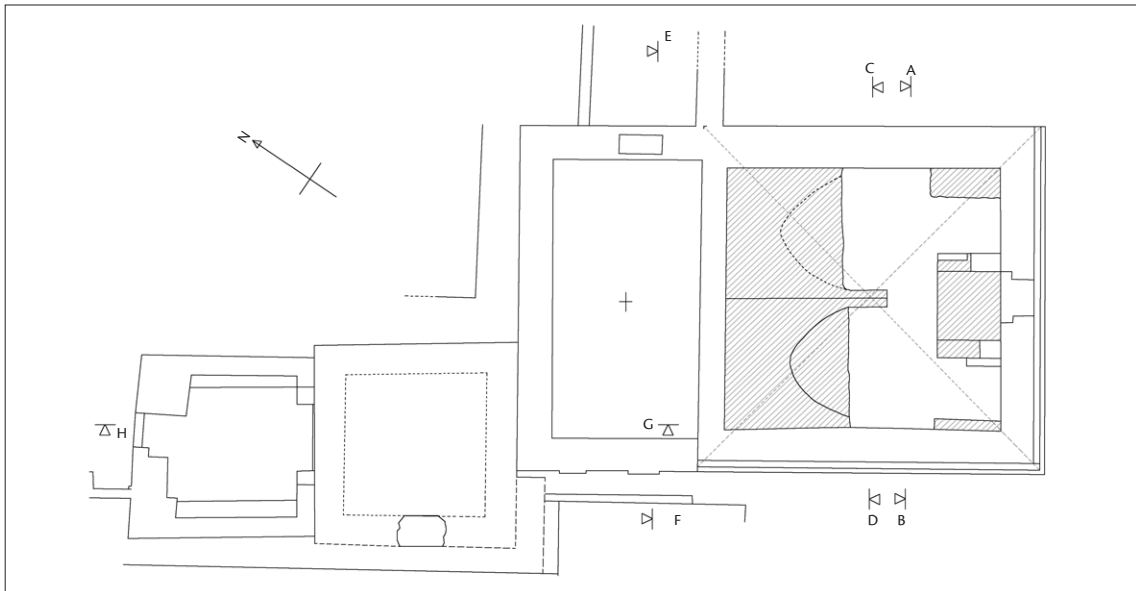

FIG. 8: Bir el-Shaghala Tomb 1, upper floor, plan.

chambers as well as the ceiling are coated with a thin layer of lime plaster decorated with a rich selection from the Egyptian books of the afterlife. The floors are paved with sandstone slabs; some have been removed by robbers in modern times.¹⁰ No traces of burial settings such as *klinai* or coffins were found in these rooms, only human bones.

The upper floor (fig. 8) is much damaged: a few courses of the mud brick walls are still present, indicating the existence of two features: a pyramidal superstructure above the two funerary chambers, and a chapel above the antechamber (figs 5, 9, 10). The south wall of the pyramid is not aligned with the south walls of the two funerary rooms, but rather extends further south for approximately 1 m (fig. 10). The remains of the pyramid show a base of 35 cm high and the extant walls reach 50 cm in height, and are 70 cm thick. The outer dimensions are not identical, as the western wall is 7.01 m, and the eastern wall is 6.81 m, while both northern

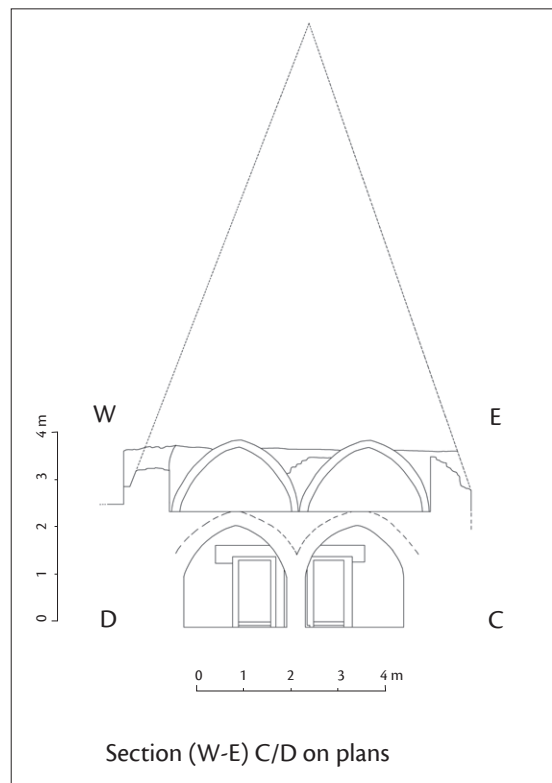

FIG. 9: Bir el-Shaghala Tomb 1, east-west section of the two floors with the pyramid restored.

¹⁰ Remains of foodstuff were found while excavating the tomb, indicating that the tombs were used or inhabited by bedouin squatters in modern times.

and southern walls measure 6.92 m in length. The mud bricks used in the walls measure $35 \times 18 \times 10$ cm. The pyramid has a steep angle of 70 degrees. Its original height with the base could be estimated as 10.03 m, which exceeds the dimensions of the Amheida pyramid, which is 7 m wide and 8 m high. Therefore this pyramid could be the largest one known from a private tomb in Roman Egypt.¹¹ It was likely topped with a stone pyramidion.

The pyramid has an opening in the south wall 65 cm in width; the remaining portion of its jambs stands to a height of 43 cm. There are two square holes on either side of this entrance, most probably to hold the lower pivots of the door. Immediately in front of this entrance, there is a staircase of three large steps, with two balustrades, descending to the floor of the pyramid. Later, this entrance was blocked, using mud bricks and the upper part of a horned altar (figs 10, 11, 12). Inside the pyramid, there are two small vaults 128 cm high, built in laterally-coursed mud bricks measuring $32 \times 18 \times 8$ cm, occupying most of the pyramid's inner space.

To the north of this pyramidal structure, there is a rectangular hall, presumably a chapel, measuring 7.30 m east-west and 4.36 m north-south, built above the antechamber on the ground floor (figs 8, 10, 13). The southern wall of this chapel is ruined, but it was rebuilt with modern mud bricks during the excavations. This wall presumably had an entrance into the pyramid, most likely with an Egyptian-type door having two inclined jambs to suit the steep wall of the pyramid. Due



FIG. 10: Bir el-Shaghala Tomb 1, view inside the pyramid on the upper floor.

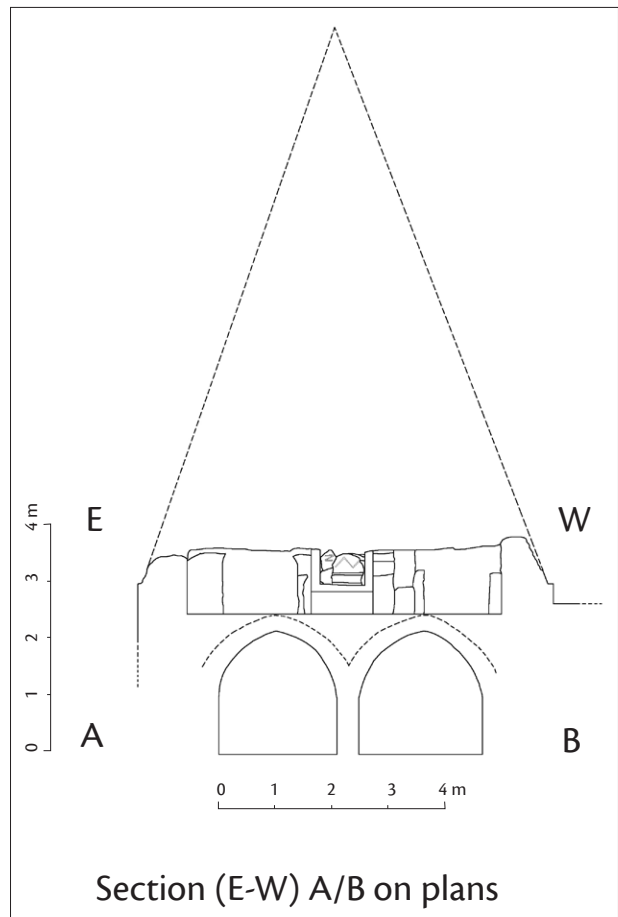

FIG. 11: Bir el-Shaghala Tomb 1, east-west section of ground and upper floors, with hypothetical reconstruction of the pyramid.

¹¹ KAPER 2015, p. 172, quotes Nicolas Warner: "The [Amheida] pyramid is the best-preserved and largest example of a Roman pyramid in Egypt."



FIG. 12: Bir el-Shaghala Tomb 1, pyramid: blocked southern entrance with original plaster coating (marked with arrow).

to the ruined condition of this part, no element of the door or the northern entrance survives, which is an important point in understanding the life of this unit of the tomb. An entrance from the chapel into the pyramid, found in many tombs in Bir el-Shaghala,¹² such as the entrance in Tomb 1, would require a descending staircase, like the southern one, owing to the lower floor of the pyramid. It is logical that when the southern staircase was blocked and the two vaults were added, the importance of the northern entrance increased, since it would have been the only access to the pyramid, if there still were one.

Further to the north are two rooms excavated in 2002, with a threshold-entrance 1.5 m wide on the east-west street. The first room measures 3.89 × 3.65 × 3.89 × 3.94 m on the north, east, south and west sides, respectively. It has two wide benches on the eastern and western walls, and a 1.43 m door in the southern wall leading to a larger room built with burnt bricks (fig. 8). The second room is a 4.4 m square; its rear wall abuts the northern wall of the Tomb 1 chapel. On the western wall, there are remains of a large *kline*-like bench, 60 cm wide, built from burnt bricks coated with plaster and then painted red (figs 14, 17). It is reasonable to suggest similar *kline*-like benches on the other two walls, forming a *triclinium*, since the white pavement is absent near the other walls.

It is apparent that Tomb 1 witnessed important changes inside and around its upper storey. First, the southern entrance to the pyramid was blocked and the staircase was levelled with mud

¹² IBRAHIM, ASHOUR 2020.



FIG. 13: Bir el-Shaghala Tomb 1, upper floor: remains of the chapel.

bricks similar to those used in the vaults (figs 8, 10, 11, 12). The two small vaults perhaps belong to this phase of use, because they extend the length of the north-south axis of the pyramid, and at least the southernmost portion of its eastern wall abutted the blocked staircase (fig. 12). The function of these two vaults was perhaps funerary, since human bones are reported from there, in addition to a single burial that was found between the eastern vault and the pyramid wall.¹³ These two vaults doubtless had their entrances in the southern side, because there is a small jamb, well indicated by the circular form of the vault spring and distanced from the blocked staircase (fig. 15). The two small doors perhaps faced each other and functioned as simple openings leading into the two small vaults.

It is not likely that a pyramid 10 m high would be hollow inside; therefore a cupola vault was probably constructed inside the pyramid. This interior space most probably had mud brick or earth filling around it to secure the pyramidal structure. Remains of larger internal walls are still visible beside the interior walls of the pyramid (figs 8, 10-13). This technique is comparable to that of the solid pyramid at Amheida, vaulted rooms inside the pyramid in the tomb of Padineith in the Asasif, Thebes,¹⁴ and the Abydos pyramidal tombs.¹⁵ It is logical to suggest that the collapse of this cupola vault led to the addition of the two small vaults. These

¹³ Reported orally by the excavators.

¹⁴ EIGNER 1984, p. 103, fig. 75.

¹⁵ PEET 1914, pp. 85-86, fig. 46.



FIG. 14: Bir el-Shaghala Tomb 1, upper floor, north side: *kline*-like room.

two vaults are certainly later additions because they are contemporary with the blocking of the southern door, and the mud bricks of which they are built are different from those used in the pyramid, in both size and their reddish colour. It is questionable whether the pyramid collapsed in this phase. No remarkable quantities of mud brick were found around Tomb 1 to indicate that the building collapsed suddenly. The possibility that its mud bricks were re-used in constructing other tombs in the necropolis requires further investigation. It is questionable as well



FIG. 15: Bir el-Shaghala Tomb 1, upper floor: entrance to the two small vaults.

whether these changes were synchronic and owing to the same reason, which necessitated the adding of wooden doors to the two funerary chambers on the ground floor. The later addition of these doors is confirmed because their pivots cut through the paintings on the doorjambs,



FIG. 16: Bir el-Shaghala Tomb 1, western side: entrance to Tomb 8A, with the heightened passage marked.

a feature also found in Tomb 5.¹⁶ These questions need further study, hopefully to clear up many aspects of the funerary practices in this tomb.

This second phase of the pyramid's life, according to the scenario proposed, requires a northern entrance to the pyramid, whose northern wall is completely ruined. If this wall contained an entrance in both phases of the upper storey, it is uncertain how this entrance could have been used with two vaults immediately in front of it. The only possibility is a gradually descending passage leading to the entrances of the two small vaults on the southern side. Nothing remains to indicate this proposed passage except mud bricks that were found between the two vaults while excavating the tomb. Are the two vaulted rooms in the upper storey of Tomb 2 with a small arched door connecting them conceptually similar? It is noteworthy that their orientation is opposite to that of the ground floor funerary chamber,¹⁷ exactly like those in the pyramid of Tomb 1, which could mark this part as a forerunner of the two mature vaulted mud brick rooms in Tomb 2.

The two rooms to the north are another interesting addition. Their connection to the tomb is clear, because the southern wall of the southern room abuts the chapel's north wall. Furthermore, they were accessible from the south as well via the remodeled passage between Tomb 1 and Tomb 8A immediately to its west. The remodeling of this passage most likely postdates the first phase of Tomb 1, because its new raised ground level had been achieved by placing three courses of mud brick against the plaster coating on both the pyramid and western

¹⁶ IBRAHIM, ASHOUR 2020, pl. 35.

¹⁷ BASHENDI 2013, p. 52, figs 2–3.



FIG. 17: Bir el-Shaghala Tomb 1, north side: earlier photo with remains of architectural modeling of the northern wall of the chapel; the pyramid of Tomb 2 appears on the left.

outer walls of the chapel (fig. 13). It is noteworthy as well that the plaster coating of the outer wall of Tomb 8A respected the existence of the three *klinai*-like benches in the first northern room (fig. 14). The 2016 season brought to light further interesting evidence concerning the pedestrian circulation on the south side of both Tomb 1 and Tomb 8A: an ascending pathway with a mud brick altar and a curving wall outlining an entrance into Tomb 8A and a passage to the two northern rooms of Tomb 1 (fig. 16).

The circular wall should belong to the entrance to Tomb 8A, but immediately to its east and before the heightened pathway there is another wall with a mud brick altar. This altar heads and marks the pathway leading to the two banqueting rooms to the north of Tomb 1. These new modes of circulation around the tomb required the re-levelling of the shared narrow passage on the west side to the level of the *kilnai* in the first room. These *triclinium*-like rooms no doubt were used for ritual or banquet purposes; the narrower first room was perhaps for reception and the larger one was used for funerary meals. They were perhaps open-air units. It is reasonable to suggest that there was an altar in front of them although none has yet been found; however, some remains of a threshold are still visible on the northernmost side (figs 8, 14). Such meals are well documented in papyri, whether to celebrate the anniversary of death according to Egyptian practice, or the birthday of the deceased according to Roman practice.¹⁸ The shape of benches inside the room with three *klinai* is very similar to the *deipneteria* in Tebtynis,¹⁹ which may confirm the banqueting function. Furthermore, the existence of many altars and an Egyptian offering table with narrow water channels and some pottery from the necropolis could suggest such funerary cults and meals.²⁰

Excavation beneath the burnt brick paved ground of the *triclinium*-like room in 2016 uncovered a mud brick wall of considerable size, but it was not possible to continue the work in this area. This wall could belong to a previous layout of an entrance into Tomb 1, which perhaps lost its importance when Tomb 2 was added, and hence the *triclinium*-like room replaced it in the second phase. The northern entrance, however, is still absent, but an earlier

18 MONTSERRAT 1992, p. 304.

19 RONDOT 2004, pp. 144–146, fig. 54.

20 NENNA 2018, pp. 65–115, esp. p. 74.

photographic record shows that the northern façade of the chapel has receding courses of mud brick, indicating some architectural stylization. It would be most reasonable to have the entrance, if there were any, in the center of the north wall. The space in front of this part was changed into a narrow passage with the addition of Tomb 2, and therefore another entrance should have been created. Furthermore, the early photographic record shows that a narrow east-west passage between Tombs 1 and 2 was blocked with mud bricks.²¹ This blocking perhaps terminated the circulation around both tombs when the access to Tomb 1 was changed from through the chapel to into the two banqueting rooms from the east-west main street (fig. 8).²² Hopefully in the near future, more excavations on these sides, which to date remain incompletely explored, will add new evidence to clarify these changes so it will be possible to understand the different architectural phases and their relationship to funerary and ritual practices connected to this tomb.

2. THE ARCHITECTURAL TYPE

Tomb 1 presents the three constant architectural components of Bir el-Shaghala tombs:²³ an open-air court, a ground floor with masonry-vaulted rooms, and a second storey with a pyramid and a chapel. To date, this architectural design is not attested elsewhere in Roman Egypt, except for the two pyramidal tombs in the Amheida south necropolis, though they are not completely explored.²⁴ The only difference is the solid core of the Amheida pyramids, but the similarity in the ground floor layout indicates the same type. Apart from the two Dakhla sites, other much smaller pyramidal tombs are known from Roman Egypt at Tuna al-Gebel,²⁵ Oxyrhynchus,²⁶ Hawara,²⁷ and Terenouthis,²⁸ and in Mahmedia (Gerrha) in Northern Sinai,²⁹ where the burial units are smaller and simpler.

The pyramid of Tomb 1 stands as a real marker, giving the tomb its distinctive typological character. Even Gael Cartron was able to figure out that it is a distinctive type, despite his dependence on very preliminary reports.³⁰ The type reflects Egyptian forerunners: aside from the royal pyramids of the Old and Middle Kingdoms, private pyramidal tombs are known in

21 This blocking wall is best shown in BASHENDI 2013, fig. 1.

22 For this street, see IBRAHIM, ASHOUR 2020, pl. 37.

23 BASHENDI 2013; IBRAHIM, ASHOUR 2020.

24 KAPER 2015, p. 171; WARNER 2004–2005, p. 65, fig. 5:2.

25 GABRA 1971, p. 74, in front of Isidora's tomb, estimated height 3 m, belonging to a certain Bisos; KESSLER, BROSE 2008, pp. 22–23; CARTRON 2012 p. 19.

26 The Oxyrhynchus pyramidal tomb, regardless of its later date, is small in dimensions and stands on a plinth, likely topping an urn. PASCUAL 2008, 40, fig. 12; CARTRON 2012, p. 19, fig. 5.

27 The Hawara pyramids are very small, ca: 77.7 × 83.5 cm; PETRIE 1911, p. 19, pl. xvii, pl. xxii 1; CARTRON 2012, vol I, p. 19; CARTRON 2012, vol. II, p. 174, figs 177–178.

28 The Terenouthis tombs show incomplete pyramids, with small dimensions; for example, Tomb 12 is 2 × 4 m and is built above a plinth; CARTRON 2012, vol. I, p. 19, fig. 3.

29 CLÉDAT 1909, p. 773; CARTRON 2012, vol. I, pp. 19–20, II, p. 106.

30 CARTRON 2012, vol. I, p. 21.

the Theban region by the late 17th³¹ and early 18th dynasties, with a remarkable concentration at Deir el-Medina.³² One Theban New Kingdom type has a pyramid above the funerary unit, like the tomb of Ipuw (TT 215).³³ Another type has a pyramid in the upper storey court with an Egyptian-style entrance with a cavetto cornice framed by two steep jambs, like the tomb of Sennedjem (TT 1).³⁴ This last feature is still preserved in Bir el-Shaghala Tombs 2, 5 and 7A.³⁵

The Memphite version of the New Kingdom pyramidal type, best attested in the tombs of Horemheb and the Tias at Saqqara, shows a pylon, portico, and colonnaded hall with a shaft leading to the substructure in addition to an antechapel and cult room. The cult room leads into a rubble-filled pyramid with a limestone casing built on a podium at ground level immediately behind and to the west of the cult room.³⁶ The tomb of Horemheb perhaps had a brick pyramid above the funerary chapel, which tops a funerary room.³⁷ The pyramidal tomb type was revived again in the Kushite and Saite periods, best attested in monumental private tombs in the Asasif, a tradition connected to the New Kingdom Theban pattern.³⁸

The Saite tombs used mud bricks on a larger scale, especially in the superstructure, which sometimes had a pyramid, but most importantly these pyramids are built above “Sargekammer”.³⁹ This feature is dominant in Bir el-Shaghala pyramidal tombs, not only in Tomb 1.⁴⁰ The pyramid of the Padeneith tomb in the Asasif is the best-preserved example,⁴¹ and like Tomb 1, its pyramid has internal spaces. The mud brick pyramidal superstructure is known as well in Cemetery IV at Abydos, which was dated by Auguste Mariette to the Middle Kingdom,⁴² although Barry Kemp argued for a date in the Saite Period,⁴³ which is now accepted by scholars.⁴⁴ The Abydos tombs present many comparable features of outstanding significance, such as the northern orientation of the pyramids, which is a rule in the Bir el-Shaghala south group of tombs, and conforms to the southern entrance to the pyramid of Tomb 1 and the proposed northern entrance. Eric Peet reported that the vaulted rooms in Abydos Cemetery E, with truncated pyramids above,⁴⁵ have a base very similar to that of Tomb 1. The existence of funerary rooms beneath or inside the pyramids of Abydos Cemetery IV⁴⁶ is comparable to Tomb 1 as well. The Egyptian-style entrance with cavetto cornice and steep jambs leading into the pyramid is in keeping with the tradition of the 18th Dynasty and stands as a link to the same feature at Bir el-Shaghala. It is possible that the superstructure of Tomb 1 in Bir el-Shaghala was influenced

31 A pyramidal tomb was located partly beneath the later ramp in the first court at Deir el-Bahari, dated to the 17th or 18th Dynasty, see WINLOCK 1914, p. 19, fig. 10; EIGNER 1984, p. 105, n. 193.

32 This type is depicted in many Theban tombs; KAMPP 1996, p. 95, n. 429, where Deir el-Medina tombs are listed.

33 BRUYÈRE 1925, pl. VI.

34 BRUYÈRE 1929, pp. 134–135, pl. XIII.

35 IBRAHIM, ASHOUR 2020.

36 MARTIN 1982, pp. 26–27, fig. 1.

37 MARTIN 1977, p. 19; EIGNER 1984, p. 105.

38 EIGNER 1984, p. 106; the type is more frequently attested in the 19th Dynasty; see KAMPP 1996, p. 96, tab. 65.

39 EIGNER 1984, p. 105.

40 IBRAHIM, ASHOUR 2020.

41 The pyramids of the Sheshonq tomb are ruined; EIGNER 1984, pp. 104–105, fig. 74, pl. 41B.

42 MARIETTE 1880, pp. 42–43.

43 KEMP 1975, p. 35.

44 EIGNER 1984, p. 104, nn. 188–189; MOSTAFA 1989, p. 125, n. 1, where they are dated to the New Kingdom.

45 PEET 1914, pp. 85–86.

46 MARIETTE 1880, pp. 42–43.

by a Ptolemaic Theban type, derived from the earlier Asasif-Abydos pyramidal tombs, with a noteworthy difference in the ground floor layout.

The ground floor of Tomb 1 presents the concept of the longitudinal antechamber leading into two funerary rooms with vaulted ceilings, which is known in many Dakhla Oasis necropoleis, such as North Tombs 1 and 2 and West Tombs 1 and 2 at Kellis,⁴⁷ and the Winlock columbarium in Sioḥ near Deir el-Hagar,⁴⁸ but the Amheida eastern necropolis still presents the closest parallel to this pattern. The partially explored northern necropolis at Amheida shows a “two-roomed structure” built in mud brick.⁴⁹ In the Nile Valley, the upper necropolis at Oxyrhynchus preserves similar masonry-built funerary rooms with vaulted ceilings.⁵⁰ The pattern could be Ptolemaic, as it is attested in Atfieh (*Aphroditopolis*), with respect to one room leading to another larger one.⁵¹ Some examples of such smaller tombs of Ptolemaic date are reported from the Asasif⁵² and Abydos.⁵³

A link to Kushite and Saite tombs could be attested in the Asasif necropolis as well, where stone rooms with a mud brick superstructure dated to the 25th and 26th Dynasties were used.⁵⁴ The Abydos type B, according to Mariette, has pyramids with two rooms beneath, the first leading to the second, the funerary chamber,⁵⁵ which is similar to the Tomb 1 ground floor in terms of function. The concept of three burial chambers fronted by a longitudinal room, as found in Kellis tombs and comparable to Tomb 1, likely depended on Egyptian temple architecture known since the 18th Dynasty in the Ptah temple at Karnak.⁵⁶ This layout continued in Egyptian temples until the Roman period, but the Qasr el-Gheuita and Deir el-Hagar temples in Kharga and Dakhla Oases respectively are interesting.⁵⁷ In funerary architecture this multi-chambered pattern was used in the non-monumental tombs of the Saite period in the Asasif necropolis,⁵⁸ but the antecedent of its combination with the pyramidal superstructure remains unknown with respect to chronology and provenance.

The pattern to date is distinctive for Bir el-Shaghala and Amheida, but a pre-Roman model is a very reasonable hypothesis. The pre-Roman model depends on the New Kingdom tombs, and their larger successors of the 26th Dynasty in the Asasif necropolis, since both have a burial shaft or sarcophagus room. This model most probably developed in the Nile valley not the oases, since Late Period cemeteries in Dakhla like Marqoula, adjacent to Mut al-Kharab, have similar multi-roomed burial spaces, sometimes constructed in stone, but still lack the pyramidal superstructure.⁵⁹ The combination of these two features perhaps occurred in the Ptolemaic period, and likely in the Theban region. The Ptolemaic period witnessed building

47 HOPE, MCKENZIE 1999, pp. 53–67; HOPE 2003, p. 252, figs 12 and 19.

48 WINLOCK 1936, pl. XXVII, Site 4.

49 MILLS 1980, p. 269.

50 PADRÓ 2007, p. 129, figs 10.2 and 10.3; CARTRON 2012, p. 242, fig. 222.

51 DARESSY 1902, pp. 161–162.

52 PM I, 2. 622; WINLOCK 1914, pp. 13–14, fig. 5.

53 PEET 1914, pp. 84–91, figs 46–50, pl. XXII; LANDVATTER 2013, p. 241, figs 5–6.

54 EIGNER 1984, p. 36, figs 11, 67.

55 MARIETTE 1880, p. 44.

56 HOPE 2003, p. 285; ARNOLD 1999, plan VIII.

57 HOPE 2003, p. 285; ARNOLD 1999, figs 45, 225, respectively.

58 BUDKA 2015, 114–120, figs 1–2.

59 YAMANI forthcoming.

of pyramidal tombs, which are known from demotic papyri.⁶⁰ Three documents come from Theban necropoleis,⁶¹ and one papyrus is from third century Tuna el-Gebel, where pyramidal tombs have deep roots and are well attested in both the dynastic and Greco-Roman periods.

Abydos cemetery E presents an interesting link in this typological development. Eric Peet, describing such vaulted rooms with superstructure, wrote:

There is, however, one tomb which seems to mark the transition stage between the early vault, with mastaba built separately over it, and the later type (probably XXVIth to XXXth Dynasties), in which the walls of the vault are continued upwards above it to form a rectangular building of some kind, so that vault and mastaba form a single structure. This transition tomb is Y9 (fig. 46, pl. XXII, fig. 3). It consists of a rectangular vault, 232 × 223 cm inner measurement, with a shaft at its east end measuring 152 × 65 cm and 189 cm in depth.⁶²

He continues to describe the superstructure of Tomb Y9 in Abydos:

To complete the description of Y9 we must describe the superstructure itself. As will be seen from the photograph and sections, it is in the form of a truncated pyramid. It rests on a platform formed of a single layer of bricks lying directly above the top of the vault, the space between the two being filled up with sand and pieces of brick without mortar.⁶³

Regardless of the debate among pioneer scholars (Mariette, Petrie and Peet), this description, when compared to the CD section of Y9 (fig. 18), indicates a pyramidal superstructure above a vaulted room, which could be a forerunner of the Ptolemaic prototype of the Bir el-Shaghala pyramidal tomb.

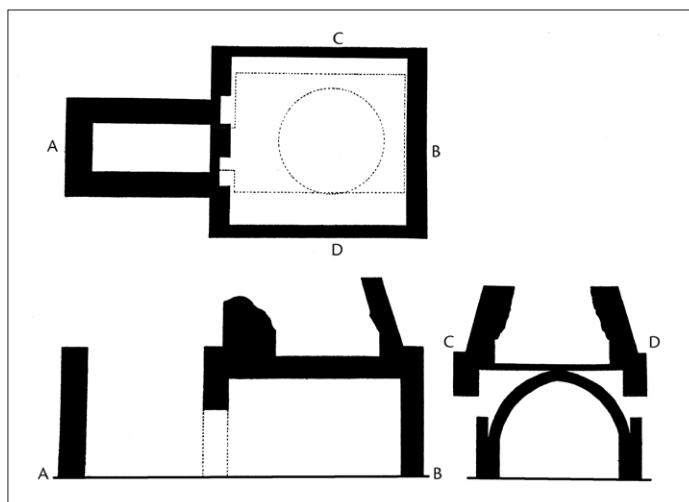

FIG. 18: Abydos, Cemetery E, Tomb Y9, section, after Peet 1914, fig. 46.

⁶⁰ BAGNALL et al. 2015, p. 340a

⁶¹ P. Dem. Amherst 58B, 60B, P. Dem. Berlin, 3116; see as well, Chicago Demotic Dictionary “M” (13 July 2010) *mr*.

⁶² PEET 1914, p.85

⁶³ PEET 1914, p. 86

This Ptolemaic prototype seems like a compact version of the Asasif monumental tombs, in which funerary units, cult spaces and an open court for offerings are topped by a pyramid and chapel in front, in addition to the characteristic multi-chambered ground floor. Abydos Cemetery E tombs lack the chapel and cultic spaces, but in terms of size conform to the monumentality of the Asasif and Bir el-Shaghala tombs. This Theban type spread to the entire Thebaid and the oases, and a conceptual equivalent of it can be traced in the Ballana pyramidal tombs, where each pyramid has a chapel in the east wall, with a cut in the rock containing a stairway leading down to the entrance to one or more burial chambers cut out of the natural rock beneath the pyramid.⁶⁴ The Ptolemaic period is a much better candidate to witness the birth of such a type, considering the evidence of demotic papyri and the attestation of the multi-chambered pattern in addition to the Abydene evidence of the simple form of the type with one room beneath the pyramid.⁶⁵

The concept of the pyramid seems to be of great significance for the owners of the Bir el-Shaghala tombs, since it once marked the entrance to the funerary unit in Tomb 5, although it denotes the entire tomb.⁶⁶ It most likely accentuated the Egyptian cultural identity and religious beliefs of the users as well. This aspect, furthermore, is stressed by the Egyptian character of the façade of the ground floor, which is similar to a “temple house” as indicated by Dieter Arnold to denote the core unit of the temple, or *naos* in the Greek concept.⁶⁷ Tomb 1 architecturally is less one to show eclectic patterns when compared to other tombs in the necropolis,⁶⁸ except for its *kline*-like banqueting rooms on the north.

3. THE DECORATION OF THE ANTECHAMBER

The entrance to the tomb has a cavetto cornice decorated with a winged solar disc painted in red, green and yellow with a horizontal torus of type E,⁶⁹ which is the commonest in the necropolis (figs 19, 20). The lintel is divided by three painted vertical red lines into two halves, each containing four figures. One can safely identify a *bj*-bird with a human head standing above a lotus flower on each side, looking inwards.⁷⁰ The second figure in the right half is a lion-headed god looking towards Osiris, while its counterpart on the left half is completely faded; this lion-headed deity most likely is Tutu.⁷¹ The third figure on each side is Osiris, with

⁶⁴ DUNHAM 1972, p. 21.

⁶⁵ LANDVATTER 2013, p. 241, commenting on the vaults excavated by Petrie and Peet with respect to the Hypogeum 1 superstructure, suggests that they “may have supported a mastaba-like structure or perhaps a dome”. This tomb has three vaulted rooms, and in our opinion a pyramidal superstructure is possible, but further investigation is still needed.

⁶⁶ IBRAHIM, ASHOUR 2020.

⁶⁷ HOPE 2003, p. 285; ARNOLD 1999, pp. 256–257, figs 96, 97, 160, 220.

⁶⁸ IBRAHIM, ASHOUR 2020.

⁶⁹ ABDELWAHED 2015, fig. 147.

⁷⁰ A *bj*-bird standing on the ground line appears in the nearby tomb of Petosiris at el-Muzawwqa, on the west wall of Room II, see VENIT 2016, pl. XXIX. This feature is frequently attested in Alexandrian tombs of late Hellenistic date, such as the Saqiya tomb, VENIT 2000, pp. 101 ff, fig. 91; VENIT 2016, pl. VII.

⁷¹ This identification is based on another figure of Tutu on the north wall of the antechamber; see below.

a feathered crown on the right and an *atef* crown on the left. The fourth figure is Nephthys on the right and Isis on the left, each with her distinctive crown. The two jambs are constructed of sandstone blocks, but they are much deteriorated; perhaps each jamb was divided into two registers by two thick red lines; in the upper register of the right jamb one can discern a figure of Anubis.



FIG. 19: Bir el-Shaghala Tomb 1, ground floor: painted entrance lintel.

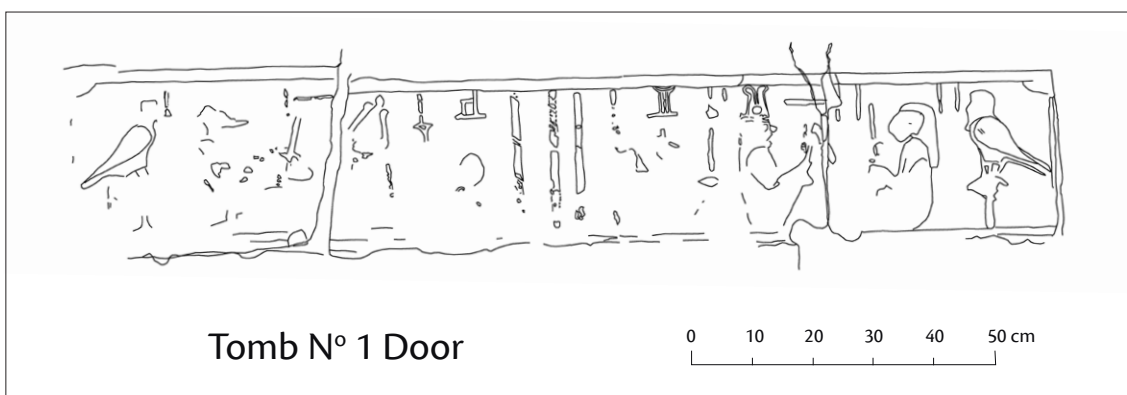

FIG. 20: Bir el-Shaghala Tomb 1, ground floor: drawing of painted entrance lintel.

The interior wall of the entrance has a large lintel exceeding the width of the doorway, decorated with a bold winged solar disc, painted green, black and red. The secondary covers of the wings are decorated with five rows of *nb*-signs, alternately painted red and green, with the wavy tails of the uraei emerging from the solar disc and lying across the marginal covers at the top of the wings.⁷² The empty space in place of the solar disc indicates it was modeled separately and inserted into the composition (fig. 21). It is best compared to the entrance to Tomb 6 in the same necropolis.⁷³ The interior surface of the two jambs is decorated with two vertical rows of *'nh ws nb*-signs painted brownish yellow on a white background.⁷⁴ The decorative pattern of the antechamber divides the walls into four registers in addition to the ceiling. The sequence of the scenes indicates an intended narrative continuity on the four walls; therefore each register on the four walls will be treated as a single unit.



FIG. 21: Bir el-Shaghala Tomb 1, ground floor, the east wall: view from inside the antechamber; *b*: of *R'*.

⁷² This detail is remarkable and is not found in other tombs in the Bir el-Shaghala necropolis, and no other parallel from another tomb can be cited with certainty.

⁷³ IBRAHIM, ASHOUR 2020, pl. 19.

⁷⁴ The motif is frequent in temple decorations; for example, the Hibis temple, Hypostyle M, DAVIES 1953, pl. 37.

The First Register

This lowest register is an undecorated space at the base of each wall 44-45 cm high, coated in white lime plaster.

The Second Register

This register is 154 cm high: It depicts vignettes from BD 125 on the eastern, northern and western walls, beginning with the *b3* of Re on the short eastern wall as a fully human figure carrying a natron vessel and a linen bandage. The black painted name reads: *b3 R'*⁷⁵ (D1 on Diagram fig. 47; fig. 21). The north wall begins with the figure of the female deceased (D2), whose name reads: *Ta-Dḥwtj s3t Ḥr-t3*,⁷⁶ dressed in an archaic tight garment, leaving her breast exposed (fig. 22). She is led by *Dw3-mwt.f* in a jackal-headed form (D3), carrying a natron vessel. Following Duamutef is a double snake-headed deity named *Hr 3 phty*: Horus great of strength (D4), carrying a vessel and a cloth bandage. The procession includes three other gods. The first, which is the only intact figure in this section, is lion-headed (D5); his name is damaged; [...] *phty* [...]: [...] strength [...] is the only remaining part (fig. 23). This god could be Tutu, despite his rare appearance with a human



FIG. 22: Bir el-Shaghala Tomb 1, ground floor, northern wall, second register, east end: Duamutef leading the deceased.



FIG. 23: Bir el-Shaghala Tomb 1, ground floor, northern wall, second register, center: Horus Great of Strength and lion-headed Tutu.

⁷⁵ The authors wish to express their gratitude to Laurent Coulon for his generous help in reading the hieroglyphic texts in the tomb.

⁷⁶ The name of the deceased appears on the ceiling of the first funerary room, where in addition her mother's name is given: *Ta-Jmn*. The authors are grateful to Laurent Coulon for this reading.



FIG. 24: Bir el-Shaghala Tomb 1, ground floor, northern wall, second register, west end: remains of the weighing of the heart scene.

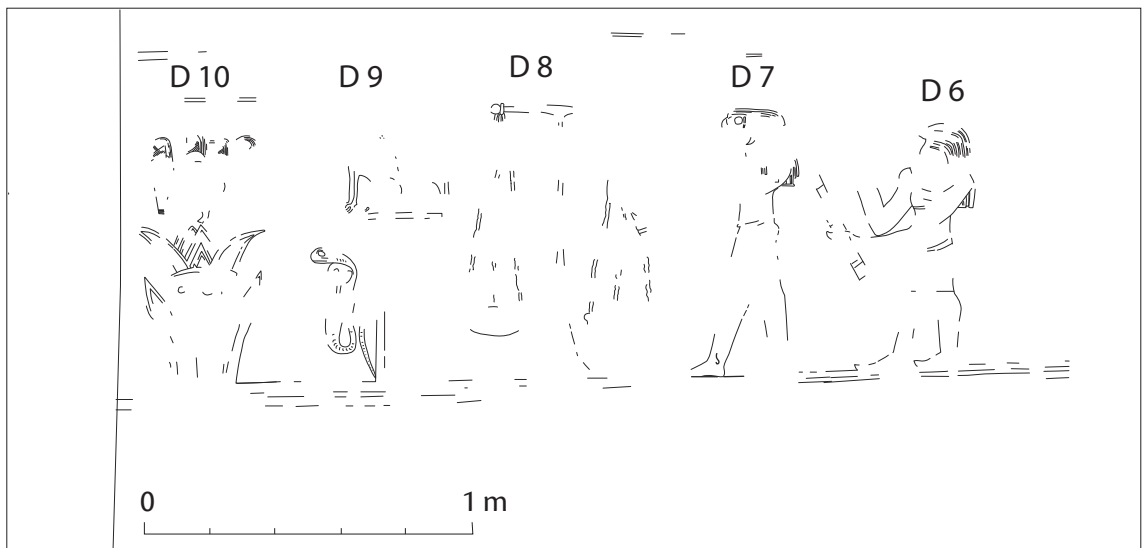



FIG. 25: Bir el-Shaghala Tomb 1, ground floor, northern wall, second register, west end: drawing of the weighing of the heart scene.

body and lion head,⁷⁷ but his presence in Dakhla Oasis is in order. The standard writing of the name as *Twtw ʕ phty* fills the lacuna perfectly. The next section depicts a judgment scene showing Thoth with a long papyrus scroll and writing instrument (D6, figs 24, 25) and a much damaged figure of falcon-headed Horus extending his hand forward (D7), touching the chain of the balance, while his left hand is raised, perhaps holding a vessel.

The following part of the scene is much damaged, but apparently it depicts a large balance painted brown (D8). The left half of the beam with three zigzag ropes perhaps imitates the chain-like form of suspension but without real holes, ending in a bowl-like weighing pan. The fulcrum of the balance is still preserved and seems to have a wider base on the ground line. The right half of the beam is completely missing, but three suspension ropes are still visible there (figs 24, 25). The much-damaged figure of *Ammit* (D9) interestingly is depicted sitting on a standard, not a shrine as usual. A rearing cobra painted green is depicted beside the standard, looking left. At the end of the wall, an elaborate bouquet with lotus blossoms and buds is still recognizable, painted in green and red, with the two lotus buds flaring diagonally on each side (D10). Above this bouquet, hardly traceable, stand the four mummiform sons of Horus looking left, most likely towards the enthroned Osiris on the adjoining western wall.

The western wall is much damaged, but the second register has the same red double border lines below and three lines above, with a band of black stars on a yellow background forming a *pt*-sign. The register begins with a figure censing in front of an enthroned Osiris, with remains of a column of hieroglyphs in front (D11). The body lines and dress favor a female figure, with tight cap, fillet and two feathers on the head. This figure is followed by an offering table (D12), from which remain only the dark yellow base and remains of offerings on a higher level above it. Osiris is depicted seated wearing an *atef* crown with flail and perhaps a scepter (D14, figs 26, 27). Two columns of hieroglyphs are much damaged but both address Osiris:

Osiris: 

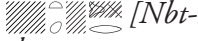
To the right: *[Wsj]r[... W]n-nfr*, [Osir]is [We]nnefer. To the left *ntr ʕ n[bt pt t] ʕ dw[ʕt]*, the [great] god mas[ter of the sky, ear]th and du[at]. The throne is decorated with successive rows of *nb*-signs, painted in green, except for the red first upper row. Behind Osiris, one can discern Isis from her crown with a column of hieroglyphs in black ink (D15):  *[ʕst w]rt*: Isis the great, followed by Nephthys, (D16) with a hieroglyphic text:  *[Nbt-hw]t [...wr]t*, [Nephth]ys [the gre]at. Remains of a yellow object that could be a *heqa* scepter appear in front of the seated Osiris (D 13), and a squatting figure of Nefertum is to be expected (figs 26, 27).

⁷⁷ KAPER 2003a, pp. 229–231, doc. R-1.



FIG. 26: Bir el-Shaghala Tomb I, ground floor, western wall, second register: enthroned Osiris.

The interpretation of the action in this register is interesting: incense is usually offered by priests, but here the feminized body lines raise doubts as to whether the deceased is depicted performing this action. Female deceased appeared offering and burning incense to Osiris in dynastic period funerary papyri⁷⁸ and in a Roman tomb in Akhmim,⁷⁹ which makes the identification of the figure (DII) as *Ta-Dḥwtj* possible. The red color used for the face and arms could be compared to a deceased female in the same Akhmim tomb.⁸⁰ The pleated garment and the thin fillet encircling the head, moreover, are attested on both male and female figures in the Roman period repertory of funerary scenes,⁸¹ but the body lines and the Akhmim tomb favor the figure of the deceased female tomb owner (figs 26, 27). The pose of the arms is comparable to many scenes of presenting an incense offering to Osiris, as is suggested by the tongue of flame and two small round objects flanking the flame, which are the typical pattern of this offering.⁸² The green and gold curved shape of the object held in the left hand suggests an arm-like censer, with its standard reversed falcon-headed terminal. The motif is

⁷⁸ With Theban provenance: the Greenfield papyrus from the 21st Dynasty, BUDGE 1913, pp. 1-2. pl. I. BM EA 9948, middle to late 21st dynasty, TARASENKO 2012, p. 387, fig. 5; NIWINSKI 1989, p. 322; BM EA 9904, NIWINSKI 1989, p.320, pl. 17a,

⁷⁹ ZOAIR *et al.* 2018, p. 183, fig. 22-23.

⁸⁰ ZOAIR *et al.* 2018, 167, fig. 5.

⁸¹ RIGGS 2005.

⁸² See FISCHER 1963, pp. 28 ff, fig. 6g, h, i; PECK 1972, p. 11, fig. 1; from the Hibis temple, see DAVIES 1953, pl. 35, 63.

To the left of the niche is the bearded figure of a *b3*-bird on a standard with a hieroglyphic text reading *b3 ntr*, the *b3* of the god. Above the niche there is a falcon with extended wings looking to its right, remarkably depicted on a red ground line. To the left of the falcon's head his name is written underlined in red:  *Hr-s3-st*. A frieze composed of two groups of three *hkr*-signs each flanking a yellow *wd3t*-eye is depicted beneath the niche (fig. 29).

The Third Register

It is a major regret that most of this register is damaged, because it presents a unique subject in tomb decoration from Roman Egypt. On all four walls, the registers have two red border lines at the top and bottom, but remarkably three border lines are used beneath the third register on both western and eastern walls, which reveals the narrative sequence intended by the artist(s) of this room. The only remains on the eastern wall within the vault show a partially damaged figure of a coiled winged cobra painted in golden yellow with black dots and strokes on a red *nb* or *hbt*-sign⁸⁸ (D17, figs 21, 30, 31). To the right in front of this cobra, a female figure wearing a tripartite wig with long lappets is depicted, likely in a squatting pose and perhaps in mummified form (D18), but remarkably her eye gazes upward, possibly denoting apotheosis. Since there is much space missing to the right, presumably the scene included another attendant (or attendants) and another winged cobra facing towards the left at the opposite end. The remains of two winged cobras flanking the scene in the same third register on the opposite western wall support the suggestion of a similar pattern on the eastern wall.

The red and white crowns on these cobras suggest they represent Nekhbet and Wadjet, rather than Isis and Nephthys (fig. 30), following a purely Egyptian tradition from the dynastic period in royal⁸⁹ and private contexts.⁹⁰ They are mostly depicted winding around a lotus flower or on a *nb*-sign on many cartonnages⁹¹ and mummy shrouds⁹² from the Ptolemaic and Roman periods.⁹³ Most interesting for the Bir el-Shaghala context is a painting from the contra-temple in Kellis, showing a male figure inside a solar disc, protected by two cobras⁹⁴ (fig. 32). An ostrakon from Mothis, showing a winged cobra above a lotus flower with the name Men-kheper-ra⁹⁵ denotes

⁸⁸ On the Boston mummy shroud (Museum of Fine Arts 50.650, RIGGS 2005, fig. 1), the sign clearly represents the abbreviation for the ritual book, *hbt*, but owing to the absence of the decorative pattern of the *hb*-sign used in the abbreviation of this word, one should consider the probability of a *nb*-sign as well.

⁸⁹ The golden throne of the pharaoh Tutankhamun has armrest inserts in the form of winged cobras, each with a double crown; see SALEH 1996, no. 179; in the tomb of Sethos I (KV 17) on the sides of the entrance to the vestibule before the funerary chamber; see HORNUNG 1999, p. 135

⁹⁰ The motif appears in private tombs by the 19th Dynasty, such as the tomb of Amun-her-khepeshef in the Valley of the Queens, the Bakenmut sarcophagus in the Cleveland Museum of Art (BERMAN-BOHAČ 1999, no. 251, pl. 26), the coffin of Kep-ha-ese in Copenhagen, remarkably protecting a *djed*-pillar, 750 BC (NIELSEN 2000, figs 25–26).

⁹¹ The series is headed by the coffin of Harsinakht, BM EA 52949, from Kharga, dated to the Ptolemaic period, (CORBELLI 2006, 49); see the cartonnage of Maries from Hawara (WALKER, BIERBRIER 1997, p. 79, no. 56; KAPLAN 1999, pl. 20), as Syros.

⁹² Boston Museum of Fine Arts 50.650, from Akhmim, 50–100 CE (RIGGS 2005, fig. 1); Metropolitan Museum of Art 44.7a (RIGGS 2008, p. 6, fig. 3), dated to the 1st century BC–1st century CE, with unknown provenance.

⁹³ The well-known treasure from Douch included two silver plaques decorated with the same motif, with red and white crowns, identified as Wadjet and Nekhbet, see REDDÉ 1992, pp. 31–32, fig. 61.

⁹⁴ KAPER 1997a, fig. 129; our gratitude to Colin Hope for this image, and permission to include it in this article.

⁹⁵ Excavated to the west side of the Seth temple in Mut el-Kharab; see HOPE et al. 2009, p. 59, pl. 14c.



FIG. 30: Bir el-Shaghala Tomb 1, ground floor, eastern wall, third register: apothosis scene.

a different religious context for the motif in Dakhla. The Bir el-Shaghala scene is unique among tomb decorations in the Roman era,⁹⁶ and lacks a parallel. The whole composition could be restored from plaster fragments in the Bir el-Shaghala storerooms, where many pieces show parts of similar winged cobras (fig. 33).

The third register on the western wall within the vault is much damaged, but remains of winged cobras are discernable; on the right there is a portion of a raised wing and a body painted in golden yellow with black dots and traces of the white crown (D19). The cobra on the left side is less clear, but a portion of its right wing, painted green and black, and a portion of the tail painted in golden yellow are still visible (D26, figs 34, 35). Between the two cobras, there are traces of four figures and two objects: the head and shoulders of a jackal-headed deity, holding a staff, appear on the far right (D20), while the missing section of the painting in front of him has room for a missing figure. Next appears what could be the

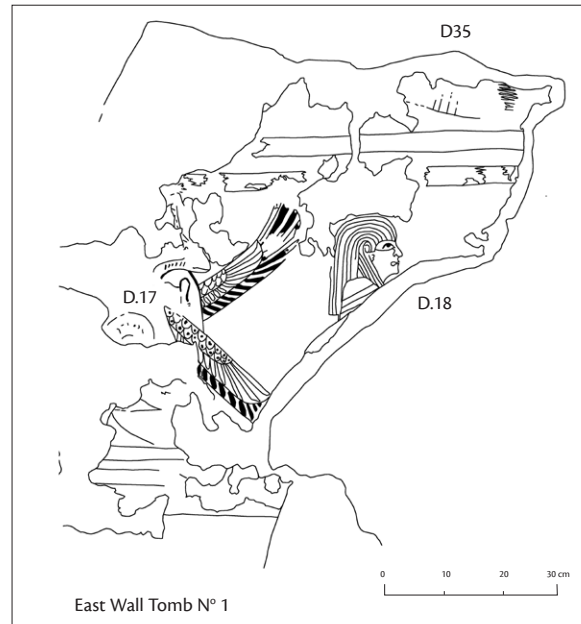

FIG. 31: Bir el-Shaghala Tomb 1, ground floor, eastern wall, third register: drawing of the apothosis scene.

⁹⁶ ADRIANI 1966; KAPLAN 1999; VENIT 2002; VENIT 2016.

blue-green base of an offering table, with a curved black line shaded in yellow springing from its base (D21, figs 34, 35). This line could be a vegetal stem ending in a lotus or another motif. The base possibly was connected to the mysterious oval object above (D22, fig. 36), which could be the flat part of an offering table, with some object(s) above it. The whole composition finds a reasonable parallel among offering tables in the main tomb at Kom el-Shugafa, and earlier in the Saqiya tomb at Alexandria.⁹⁷ More likely it could be similar to the “high pedestal or altar” with unclear object above in the Sieglin tomb from Gabbari in Alexandria.⁹⁸ Two similar offering tables with similar vegetation springing from the base and two vases above decorated in lotus sepals in the Persephone tomb in Alexandria are very comparable.⁹⁹

To the left of the proposed offering table two staffs appear (D23); their being a part of the scene is based on their painting in yellow and black shaded lines like the rest of the figures in the same register. These two staffs are thicker than those that appear in hands of Duamutef and the far left figure, which suggests they are actually standards, perhaps topped with figures of deities, since the space between them is not sufficient for a figure. This pattern could be compared to two similar objects on the coffin of Didyme in el-Minia Museum.¹⁰⁰ To the left of the second standard there are two feet with a garment edge remaining from a human figure painted in green (D24). The figure on the far left is dressed in a long garment too, and a portion of his right arm is still visible, holding a staff, but most likely he was squatting not standing (D25, figs 34-35).¹⁰¹ Therefore the Duamutef on the far right was probably squatting as well, and the striding figure on the left indicates a similar pose for the missing figure on the right. Given the presence of a jackal-headed deity and calculating

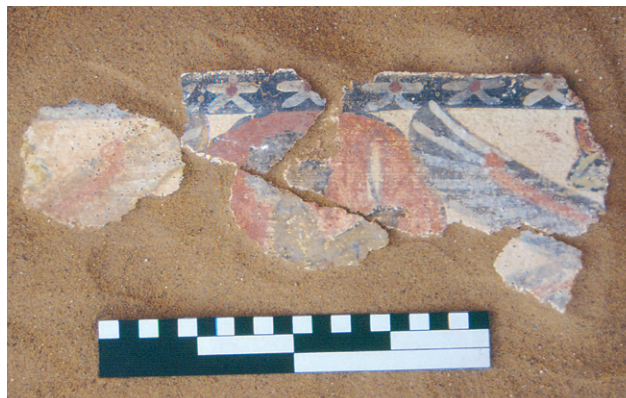

FIG. 32: Kellis, painting from the contra-temple, reproduced courtesy of C.A. Hope, Dakhleh Oasis Project.



FIG. 33: Bir el-Shaghala Storerooms: fragments of plaster with parts of winged cobras and serpents.

⁹⁷ KAPLAN 1999, pl. 68b.

⁹⁸ SCHREIBER 1908, p. VII, fig. 1; VENIT 2002, p. 124, fig. 102, better images are in GUIMIER et al. 2017, fig. 78.

⁹⁹ GUIMIER et al. 2017, p. 106, fig. 103.

¹⁰⁰ KURTH 1990, pl. 7.1.

¹⁰¹ Our gratitude should be addressed to Cynthia Sheikholeslami for remarking on this scene.

that there are four figures in the scene, it is most likely they should be identified as the four sons of Horus. An earlier pattern with figures of the four sons of Horus depicted on cuboid thrones appears in the tomb of King Ay, flanking an offering table as well.¹⁰² The two striding figures in this scene, in addition to the offering tables and standards, may suggest other identifications, perhaps the deceased or some deities in connection with a specific action in the narration.



FIG. 34: Bir el-Shaghala Tomb I, ground floor, western wall, third and fourth registers: sons of Horus and the solar boat.

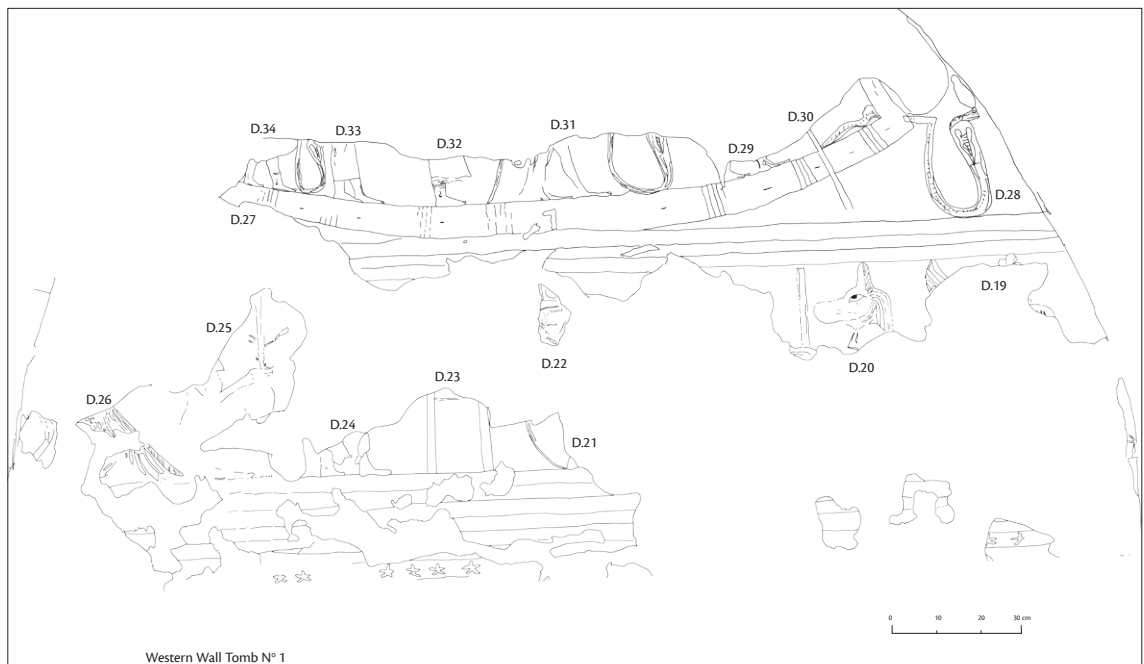

FIG. 35: Bir el-Shaghala Tomb I, ground floor, western wall, third register, drawing of the third and fourth registers on the western wall.

¹⁰² PIANKOFF 1958, pl. XXV.

The third register on the north wall begins with a figure of Wepwawet in jackal form painted black, standing on a *shedshed*-sign standard steadied by a *w3s*-sign with arms. Below and in front of the standard is an emblematic group of *nfr-w3s-nb*-signs (figs 22, 45). The jackal's front paws step on a rearing cobra painted in green,¹⁰³ a common motif in Egyptian temple decoration.¹⁰⁴ The southern wall seems to have an identical pattern; on the very eastern edge there is an egg or perhaps a lunar disk¹⁰⁵ on a standard following an ibis standing on top of a shrine which is painted in yellow with a white cavetto (fig. 37). The ibis is painted in black and white with a red solar disc with a lunar crescent painted yellow on its head. The westernmost end shows the lower part of a standard, painted dark yellow (fig. 28), possibly carrying the figure of a deity, balancing the ibis figure at the opposite end of the same register. The distance between the standards on both walls seemingly was occupied by a long hieroglyphic text in two large lines, which is better preserved on the northern wall (figs 22, 23). The southern wall text is still retaining few signs (fig. 37), which could be the end of the first part of the text that continues on the northern wall, which is an Osirian liturgy, well attested in Roman tombs in Dakhla Oasis (such as the tombs of Kitynos, Petosiris and Petubastis) and attested on a funerary bed from Kellis, in connection with the Sokar and Khoiak festivals.¹⁰⁶



FIG. 36: Bir el-Shaghala Tomb 1, ground floor, western wall, third register: detail of the upper part of the offering table in the sons of Horus scene.

¹⁰³ For Wepwawet on *shedshed*-emblem, see DUNAND 2012, p. 152, fig. 242.

¹⁰⁴ Hibis temple, DAVIES 1953, pl. 3, 4, 33, 47.

¹⁰⁵ Our gratitude is addressed to Cynthia Sheikholeslami for this remark.

¹⁰⁶ See the Annex with full bibliography.



FIG. 37: Bir el-Shaghala Tomb 1, ground floor, southern wall, third register: ibis standard and *ḥ.k*-formula.

The Fourth Register

The fourth register on the western wall is slightly more recognizable. It depicts the sun boat (D27), but unfortunately the upper part is damaged. On the far right, the serpent suspended from the prow of the boat wearing the white crown, which could be Isis or Nephthys, functions as an anchor (D28, figs 34, 38). Remains of five figures (?) appear on the boat; the first on the right has bare feet and the lower portion of a pale brown garment (D29); in front of him the sounding pole is depicted in yellow, passing over the side of the boat (D30); therefore it could be Anubis. The second figure has two bare legs painted green with the lower part of a rearing green cobra in front; its tail appears behind him (D31). The whole figure is the ram-headed nocturnal form of God Re protected by the serpent *Mhn*. The third figure also has bare feet and a portion of a brown garment, but most interestingly with three anklets on the leg itself (D32), which may indicate the figure of a deity (?), since these anklets appear on depictions of deities in Egyptian temple reliefs.¹⁰⁷ Another figure appearing on the left is dressed in a tight-fitting white garment with its feet painted green; the position of the feet suggests a female (?) figure, and the skin color indicates she is a goddess or perhaps the justified deceased (D33). Finally,

¹⁰⁷ For example, in the Hibis temple, see DAVIES 1953, pl. 17.

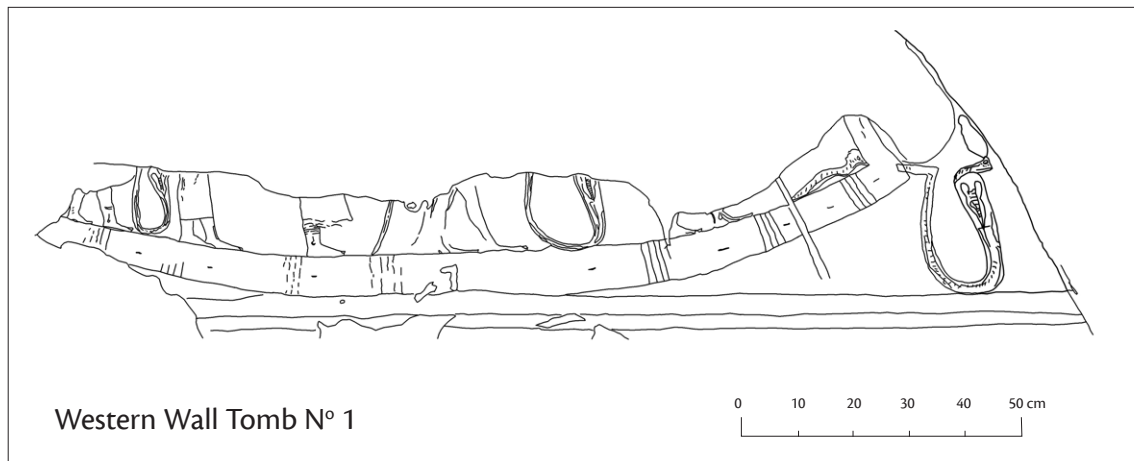

FIG. 38: Bir el-Shaghala Tomb I, ground floor, western wall, fourth register: drawing of the solar boat.

behind her is a rearing green serpent and two bare striding legs, which may indicate another god holding the steering rudder with a serpent suspended from the top (D34). On the western wall, just beneath the curved edge of the vaulted ceiling, there are some traces of a winged solar disc, whose existence in this location seems reasonable (fig. 34).

The fourth register on the eastern wall is almost completely lost, but the remaining plaster shows traces of a monumental painting of a golden yellow subject, perhaps a solar boat (D35, figs 21, 30, 31). The four vertical lines perhaps indicate a rope band tying the papyrus stalks together, very similar to the boat on the western wall and another boat depicted in the second funerary room in the same tomb. The presence of the the day barque of the sun god is reasonable, since the western wall's fourth register has the night barque of the sun god.¹⁰⁸ The summit of the vaulted eastern wall was presumably, like the western one, decorated with a winged sun disc, according to Egyptian norms (figs 21, 34).

The decorative pattern of the ceiling seemingly begins on the north and south walls immediately above the third register. A portion of the pattern of red stars on a yellow background still remains above the Osirian liturgical text on the north wall (fig. 22). The same pattern of red stars is still traceable above the shrine with ibis on the south wall, with the remaining portion of a female figure, who could be the goddess Nut wearing an ankle-length garment with a decorated hem (fig. 37). The north wall shows traces of the toes of a left foot above Wepwawet in the third register (fig. 45). This foot could belong to another Nut figure, supposedly balancing the figure on the south wall. The existence of many plaster fragments from the tomb with red stars supports this hypothesis. The whole pattern perhaps included two extended figures of Nut, stretching from the east to the west walls. This reconstruction could be confirmed from the Nut figures in the two funerary rooms of the tomb, extending from the entrance door wall to the rear wall as well. The pattern is known in Egyptian temples, but geographically appears close by in Kellis Shrine I¹⁰⁹ and at the Deir el-Hagar temple.¹¹⁰

¹⁰⁸ Our gratitude is addressed to Cynthia Sheikholeslami for her valuable remarks that enhanced the reconstruction of the scenes on the east and west walls.

¹⁰⁹ KAPER 1997b, p. 205, fig. 1, pl. VIII.

¹¹⁰ KAPER 1997a, pl. 10a.



FIG. 39: Bir el-Shaghala Tomb 1, remains of plaster frieze (1) with *bj* birds.

The red star motif on the ceiling helps suggest the interpretation of other plaster fragments showing an intact section of painted frieze between two border lines depicting *bj*-birds, once with the same pattern of red stars on a yellow background below (figs 39, 40). However, these border lines are only 10-12 mm wide, which differentiates them from any border lines on the walls, which vary between 3 and 5 cm in width. This frieze was perhaps longer, including other *bj*-birds, and accordingly, many plaster fragments from Tomb 1 showing similarly painted *bj*-birds looking to their right might belong to it. These *bj*-birds are characterized by painted faces, less detailed ears, extremely long noses, reminiscent of the face of the tomb owner on the north wall (fig. 22), and tight-fitting head gear (figs 41-42). Therefore the whole pattern included the two figures of Nut with the red stars on a yellow background, in addition to lengthwise frieze(s) with *bj*-birds.



FIG. 40: Bir el-Shaghala Tomb 1, remains of a plaster frieze (2) with *bj* birds.

The 10-12 mm red border line calls attention to another valuable item: a plaster fragment with two of the same border lines above a painted frieze. The two lines frame a *tyt*-sign beside an Abydos fetish, which connects this frieze to the ceiling, not the walls (fig. 43). Another plaster piece shows a *tyt*-sign that can hint that the original composition was perhaps *tyt*-signs alternating with the Abydos fetish. It is very questionable whether the *bj*-birds and the Abydos fetish once belonged to the same lengthwise frieze. Alternatively, there were two friezes decorating the ceiling. Worth mentioning is that the design of the two protective serpents on the Abydos fetish on this plaster fragment is attested only in Tomb 1, since a similar scene depicted in Tomb 2 is different.¹¹¹ These remarks may confirm the attribution of these plaster pieces to Tomb 1, and suggest that the *tyt*-signs and Osiris fetish were a central emblem in the ceiling. For the moment it is possible to entertain the two possibilities, since no parallel is known from Roman Egypt, either from a tomb or other funerary objects.¹¹²

¹¹¹ BASHENDI 2013, figs 17, 18, 19.

¹¹² A cartonnage fragment from Dabashiya in Kharga Oasis shows a band of *tyt*-signs alternating with *djed*-pillars, DUNAND, IBRAHIM, LICHTENBERG 2012, p. 52, fig. 56.



FIG. 41: Bir el-Shaghala Storerooms: plaster fragment (1) depicting a *bꜣ* bird.



FIG. 42: Bir el-Shaghala Storerooms: plaster fragment (2) depicting a *bꜣ* bird.



FIG. 43: Bir el-Shaghala Storerooms: plaster fragment depicting the Abydos fetish between two *tyt*-signs.

4. STYLISTIC STUDY AND DATING

The decoration of the tombs at Bir el-Shaghala necropolis stands at the same level of elaboration as the architectural design, since they are the best preserved painted tombs in comparison to many other necropoleis in Dakhla Oasis. The Ezbet Bashendi tombs, especially that of Kitynos, show similar subjects, but they are executed in relief.¹¹³ The two often noted tombs at el-Muzawwaqa, the simply designed rock-cut tombs of Petubastis and Petosiris, present the closest parallel to the Egyptian decorations of Tomb 1.¹¹⁴ The earlier photographic record of North Tomb 1 at Kellis shows few common stylistic elements¹¹⁵ despite the similar vaulted funerary chambers of the Kellis tombs, whose damaged painted decorations are much regretted. From a wider perspective, these decorations conform to those of the Roman era tombs in Alexandria and the *chora*, especially at Tuna el-Gebel and Akhmim, with some anomalies which are not known anywhere else until now.

The depiction of the *b3* of Re as a human figure (D1, fig. 21) is not attested elsewhere in Roman era tombs in Egypt. In addition, the lion-headed Tutu (D5, fig. 23) is otherwise known only in temples. The particular arrangement of the sons of Horus with two protective cobras, most probably on two registers with a continuous theme and narration, still lacks a parallel (figs 34, 35). The apotheosis scene with two protective cobras, despite the lacuna, is still unique as well. The frieze of *b3*-birds with the *tyt*-signs flanking an Osiris fetish is unique, so far as is known.

The vignettes of chapter 125 of the *Book of the Dead* on the east, north and west walls are arranged in the typical pattern used in Roman times, like the tomb of Petosiris at al-Muzawwaqa and sarcophagi like those of Teuris and Didyme,¹¹⁶ in terms of dress, movement, vessels and bandages carried in hands, regardless of the different attendants. The Anubis leading the procession in the tomb of Petosiris is very close to the jackal-headed figure of Duamutef on the north wall (D3), with his head turning backward and his tripartite wig (fig. 22).¹¹⁷ The execution is comparable to funerary stelae from Abydos dated to the 1st century CE,¹¹⁸ but the motif goes back to the dynastic period.¹¹⁹ The painter of this scene finished the figure with an error of perspective for the wig lappet on the left side, which may indicate that he was less familiar with such complicated details, although it does indicate the elaborateness of the model imitated in this figure. The presence of Tutu in an oasis tomb is reasonable (D5), but Horus great of strength (D4), with double serpent head, is unparalleled in Roman period tombs. An interesting and similar representation is known in the chapel of Meroitic pyramid no. 14,¹²⁰ which may indicate Theban influence at both sites.

The position of two hands at equal height in a non-adoring gesture is not very uncommon: a good parallel appears in the tomb of Petosiris, particularly in the second room, with male

¹¹³ YAMANI 2001. For other rock cut tombs, but without decoration, in the Dakhla Oasis, see BASHENDI 2012.

¹¹⁴ WHITEHOUSE 1998, pp. 253 ff; VENIT 2016, pp. 157 ff.

¹¹⁵ HOPE 2003, p. 207 ff; KAPER 2003b, pp. 223–230.

¹¹⁶ KURTH 1990, pp. I-II, pp. 33–35. Pl. 1–5, pl. 6–8.

¹¹⁷ OSING 1982, pl. 26; VENIT 2016, p. 170, fig. 5.13.

¹¹⁸ RIGGS 2005, fig. 79.

¹¹⁹ The stela of Pa-sheri-em-menu in Leiden, see SEIPEL 1989, p. 263, no. 467, dated to the Third Intermediate Period.

¹²⁰ LD, V, pl. 39

and female deities,¹²¹ and on a cartonnage fragment from el-Deir north necropolis in Kharga Oasis, dated to the Roman period.¹²² The same position is attested on a mummy shroud in Philadelphia, dated to the early Roman period,¹²³ and for the figures of Horus and Anubis on a funerary bed in Berlin, dated to the mid-2nd century CE.¹²⁴ The exaggeratedly elongated hands with curving fingers, reflecting the weight of the vessel they carry, are remarkable, and find a good parallel on the Cleveland cartonnage, which belongs to the “Kharga Coffin Group”,¹²⁵ and among the paintings in House 21 at Tuna el-Gebel.¹²⁶ The Moritz photographs of Kellis Tomb I show a similar treatment of the hands.¹²⁷ This style is derived from a Theban tradition rooted in New Kingdom tombs. Such Theban influence, or Theban archaism as Christina Riggs terms it,¹²⁸ is well attested in Dakhla Oasis during Roman times.

The style of execution of the mummy bandages with two ends merging together, appearing as a suspended fold of cloth, is not attested in el-Muzawwaqa tombs, but the earlier photographic record by Moritz of Kellis North Tomb I shows similar painted bandages with the sons of Horus.¹²⁹ In the Nile Valley, this feature is well attested at Tuna el-Gebel in House 21 and on a cartonnage in the Louvre attributed to that site on a stylistic basis.¹³⁰ It also appears on the Teuris coffin in Amsterdam from the first half of the 2nd century CE.¹³¹

The figure of *Ta-Dḥwty* on the north wall (D2, fig. 22) finds a good stylistic parallel in the Isis and Nephthys figures in the tomb Von Bissing 1897 at Akhmim,¹³² dated to the 2nd century CE. The dress and the body modelling are very similar, with an exaggerated abdomen. The execution of the body with the breast exposed is attested in the second room of the tomb of Petosiris,¹³³ and on a funerary bed in Berlin from the mid-second century CE, attributed to Thebes on the basis of linguistic evidence.¹³⁴ The wig of *Ta-Dḥwty* has parallels in the figure of a goddess within an offering scene in the tomb of Kitynos, one of the year goddesses from the Amheida sanctuary dedicated under Domitian, the goddess in the Deir el-Hagar pronaos,¹³⁵ and the Didyme figure on her sarcophagus,¹³⁶ where the modelling of the back lappet of the wig is similarly curved in form and follows the shoulder line.¹³⁷

The scene of weighing the heart (D6-10, figs 24, 25) is best compared to the tomb of Petosiris: the same attendants are depicted, including *Ammut* and the four sons of Horus on a flower in

121 VENIT 2016, pp. 175 ff, figs 5.17, 5.18.

122 DUNAND, HEIM, LICHTENBERG 2012, fig. 443; TALLET 2014, fig. 5b.

123 KURTH 2010, p. 106.

124 KURTH 2010, p. 116, fig. 11.

125 TALLET 2014, fig. 8.

126 VENIT 2016, pp. 113 ff, figs 4.8–4.25, pl. XIV–XVIII.

127 SCHREIBER 1908, p. 156, n. 50, fig. 88.

128 RIGGS 2005, p. 175.

129 SCHREIBER 1908, fig. 88; KAPER 2003b, p. 324, pl. 1.

130 AUBERT 2008, Cat. 19.

131 KURTH 1990, p. 1, pl. A1.

132 VENIT 2016, p. 186, fig. 5.29.

133 VENIT 2016, pp. 175 ff, figs 5.17, 5.18, 5.21, 5.22.

134 KURTH 2010, p. 191, abb. 39.

135 KAPER 1997a, figs 12, 24.

136 KURTH 1990, pl. 7.

137 YAMANI 2001; BAGNALL et al. 2015, p. 168, fig. 88.

front of Osiris.¹³⁸ The Tomb 1 scene shows *Ammit* depicted on a standard, not a shrine, which is a rare motif only attested on a single funerary papyrus, so far as known.¹³⁹ The balance resembles *Libra Romana*, but finds a close parallel in the balance erected in the second room of the tomb of Petosiris with the pommel-like terminal of the beam, despite the different shape of the suspension ropes and the lotus flower in the Muzawwaqa tomb.¹⁴⁰ The same scene presents a closely similar pose of the figure of Thoth with the long, diagonally held scroll and the writing instrument, but the Muzawwaqa figure is leaning forward while the Tomb 1 figure stands straight. The scene shows another rare feature: the attendants are depicted in front of the balance. However, a few parallels are known: a coffin in Amsterdam,¹⁴¹ a mummy shroud from Meir,¹⁴² and a funerary bed in Berlin with a different form of balance.¹⁴³

The much-damaged western wall presents a very common subject in tomb paintings: the censuring in front of Osiris, but its peculiarity is based on its performance by the deceased with censor. Dynastic period funerary papyri show a vessel carried by the deceased,¹⁴⁴ while in the Akhmim tomb,¹⁴⁵ the deceased is burning incense above the altar; nevertheless, the action remains comparable. A very similar composition of the scene is attested in Tomb 3 from the Roman period at Oxyrhynchus; the only difference is the priest censuring and the absence of the two feathers on his head.¹⁴⁶ These feathers are known in the Kom el-Shougafa main tomb central niche and in House 21 in Tuna el-Gebel. They appear as well on a mummy cartonnage from Hawara,¹⁴⁷ and on the mummy cartonnage of Kerasher dated to the Augustan period.¹⁴⁸ The feathers may denote the rank of *pterophoros* or *hierogrammateus*, usually depicted reciting from a papyrus, like the Tuna el-Gebel scene.¹⁴⁹ The Bir el-Shaghala scene is unique in combining these feathers with the deceased censuring. The whole scene perhaps imitated a papyrus,¹⁵⁰ or another funerary object. The scene is very fragmentary, but the Osiris figure (D14), with its delicate body lines and youthful appearance, is comparable to the Osiris from House 18 in Tuna el-Gebel.¹⁵¹ The pattern of successive *nb*-signs on the throne of Osiris does not have any parallel to date, but it appears again in Tomb 1 on the wings of the solar disc on the interior of the entrance lintel, in rows of alternating colors (fig. 21), which may reveal a very personal style of the painter, and confirm the stylistic uniformity of these two walls.¹⁵²

138 KAPLAN 1999, pl. 110b; VENIT 2016, p. 177, fig. 5.19.

139 The funerary papyrus of Atmen in the Louvre, of late Ptolemaic date, shows *Ammit* standing on a similar standard, see SEIPEL 1989, p. 183, no. 147.

140 VENIT 2016, 178, fig. 5.19.

141 KURTH 1990, Colour, pl. A.

142 PARLASCA, SEEMAN 1999, p. 210, pl. 206 e.

143 KURTH 2010, fig. 31.

144 TARASENKO 2102, p. 387, fig. 5; NIWINSKI 1989, p. 320, pl. 17a.

145 ZOAIR *et al.* 2018, figs 22-23.

146 PADRÓ 2007, p. 133, fig. 10.4.

147 WALKER, BIERBRIER 1997, p.39, no.12.

148 SEIPEL 1989, no. 148-149. O. Kaper (1997, p. 109-110, fig. 58), discusses the titles of priests on the north wall in the Kellis Mammisi, the title *hry-sšw* appearing, but the feathers are missing in the fragmentary scene.

149 VENIT 2016, p. 215, n. 455.

150 SEEBER 1976, p. 52, fig. 4.

151 GABRA 1941, pl. 13; VENIT 2016, p. 111, fig. 4.2.

152 This observation can be confirmed by a figure of an enthroned deity (perhaps Osiris?) in the eastern funerary room, where the throne is decorated in a different and less symmetrical pattern.



FIG. 44: Bir el-Shaghala Tomb 1, ground floor, western wall, second register: blue lotus frieze beneath the throne of Osiris.

The row of flowers beneath the throne is interesting (fig. 44). The blue lotus is common in Dakhla tombs such as that of Petubastis,¹⁵³ with a different palette, and the North Tomb 1 in Kellis, with different execution of the flowers.¹⁵⁴ Interestingly, the motif is not attested in other tombs in Bir el-Shaghala or in other spots in Tomb 1, but it best compares to the “Kharga Coffin Group”,¹⁵⁵ such as the cartonnage in Cleveland and that of Panakht in Berlin.¹⁵⁶ The Cleveland painter used the same palette: yellow, green and red with black outlining.¹⁵⁷ Such stylistic affinities suggest some connection between the Kharga workshop and the painter of this western wall. The unbound bouquet of lotus blossom and buds beneath the four sons of Horus stylistically follows the same pattern with elongated buds, very comparable to Kellis North Tomb 1 and to mummy shrouds as well.¹⁵⁸ A sarcophagus in London, BM EA 6708, dated to the early 2nd century CE,¹⁵⁹ shows a similarly composed unbound bouquet, although it is likely to postdate the Tomb 1 motif.

The southern wall most likely was painted by two painters, although one can notice the same hand that executed the paintings on the northern wall in the Horus and Anubis figures on the southern wall (fig. 6). The *tyt*-signs flanking the *djed*-pillar, and the paintings around the niche were perhaps executed by a third hand (figs 28, 29). A *djed*-pillar topped by a human head with shoulder-length hair is well attested in tombs,¹⁶⁰ coffins and shrouds from Greco-Roman period,¹⁶¹ but the concept is traceable back to the 21st Dynasty.¹⁶² The tomb Von Bissing 1897

¹⁵³ VENIT 2016, p. 161 f, fig. 5.6.

¹⁵⁴ This flower appears in Von Sieglén's reproduction of Winlock's photograph; see SCHREIBER 1908, p. 157, fig. 94.

¹⁵⁵ RIGGS 2005, pp. 73 ff.

¹⁵⁶ GERMER 1997, pp. 87–91; RIGGS 2005, p. 258, no. 2, figs 19–21.

¹⁵⁷ BERMAN, BOHAČ 1999, pp. 503–505 (no. 399); RIGGS 2005, p. 258, no. 3; TALLET 2014, p. 394, fig. 8.

¹⁵⁸ A mummy shroud in Moscow shows a similar unbound bouquet, above which stand the sons of Horus; see KURTH 2010, pp. 34ff, 49, fig. 2, dated between 50 BC–50 CE.

¹⁵⁹ RIGGS 2005 no. 79, fig. 86.

¹⁶⁰ One example is known from a tomb in Akhmim: VENIT 2016 p. 186, fig. 5.29, thinks about a fetish of Osiris, and House 21 in Tuna el-Gebel, VENIT 2016, p. 115, fig. 4.6.

¹⁶¹ A mummy shroud in Cairo shows a very similar figure of a bust in Egyptian style, see CORCORAN 1995, p. 46 f, fig. 12.

¹⁶² VENIT 2016, p. 115.

in Akhmim presents the closest parallel, but the *djed*-pillar has four bars, not three bars like the Tomb 1 *djed*-pillar, and the head has shorter hair. The three-barred *djed*-pillar is known in oases contexts: two cartonnage fragments from Ain Labakha,¹⁶³ and the Paopes cartonnage from Kharga in Heidelberg.¹⁶⁴ On the other hand, there are depictions of *djed*-pillars from the oases showing four bars,¹⁶⁵ which may mark the feature in Tomb 1 as a personal interpretation of the artist, since it appears at non-oasis sites like Hawara,¹⁶⁶ and on a Ptolemaic canopic chest from Saqqara in Mariemont.¹⁶⁷

The form of the stand of the *djed*-pillar on the same southern wall is remarkable, and no parallel has so far been located among Roman era tombs, but its cloth-like shape is comparable to a *djed*-pillar figure on a papyrus from Bab el-Gusus.¹⁶⁸ It is questionable whether this form symbolizes unification with the *tyt*-sign. Furthermore the “open” *tyt*-signs usually have extended side knots in Tomb 1, not the commoner “closed *tyt*-sign”, which appears frequently in Dakhla tombs: the Kitynos tomb, Tomb 2 in Bir el-Shaghala,¹⁶⁹ and the Muzawwaqa Petosiris tomb, remarkably in Room II.¹⁷⁰ The Abydos fetish in the left-hand scene on the same wall has a similar stand (fig. 29) but it is very remarkable that it is decorated in dotted bands, like the two *tyt*-signs beside the *djed*-pillar on the other side of the wall (fig. 28). The dotted band decorating the *tyt*-sign (fig. 28) seems to be very common among the cartonnage workshops in Kharga Oasis: it is attested from el-Deir,¹⁷¹ Ain Labakha,¹⁷² Dabashiya on a remarkable cartonnage fragment,¹⁷³ and above all in the “Kharga Coffin Group”.¹⁷⁴ This feature, which is not attested in other tombs from Bir el-Shaghala or in the two painted tombs at el-Muzawwaqa, may add another link between the painters of Tomb 1 and the artists of the coffin ateliers in the Great Oasis. The cartonnage coffins from Dakhla Oasis are less known, but at least the red color and white rosette bands are attested on some cartonnages from Kellis, which may confirm the stylistic affinities to Kharga workshops.¹⁷⁵ The falcon figure above the niche on this south wall is very comparable to the falcon on the short side of the coffin of Sennesis in Amsterdam,¹⁷⁶ and presents further evidence of this Kharga influence. The execution of the two figures is very close in style: the arrangement of feathers and the movement and beak of the bird pinpoint the origin of such an execution, especially when compared to the sarcophagus of Didyme from Zaweit el-Amwat.¹⁷⁷

¹⁶³ IBRAHIM *et al.* 2008, p. 153, fig. 272, p. 162, figs 283–286.

¹⁶⁴ TALLET 2014, fig. 7b.

¹⁶⁵ From Dakhla, the Petosiris tomb, see VENIT 2016, pp. 177 ff, figs 5.17, 5.21, from Kharga, the Louvre sarcophagus, see RIGGS 2005, pp. 73 ff, fig. 17, a cartonnage fragment from el-Deir necropolis, DUNAND, HEIM, LICHTENBERG 2012, fig. 479, and another cartonnage fragment from Ain Labakha, IBRAHIM *et al.* 2008, fig. 264.

¹⁶⁶ BM EA 22108, from Hawara, WALKER, BIERBRIER 1997, p. 80, no. 57.

¹⁶⁷ DERRIKS, DELVAUX 2009, p. 364.

¹⁶⁸ NIWINSKI 1989, p. 280, fig. 44 b.

¹⁶⁹ BASHENDI 2013, fig. 17.

¹⁷⁰ VENIT 2016, pp. 177 ff, figs 5.17, 5.21.

¹⁷¹ DUNAND, HEIM, LICHTENBERG 2012, figs 243, 479.

¹⁷² IBRAHIM *et al.* 2008, p. 147, fig. 264.

¹⁷³ DUNAND, IBRAHIM, LICHTENBERG 2012, p. 52, fig. 56.

¹⁷⁴ The Heidelberg cartonnage, TALLET 2014, fig. 7b.

¹⁷⁵ HOPE 2014, fig. 13 b, c. Our gratitude to Colin Hope for his further remarks that “connection with and dissimilarity to the Kharga cartonnage style has been documented for the Kellis cartonnage” (personal communication).

¹⁷⁶ RIGGS 2005, pp. 73 ff, fig. 16.

¹⁷⁷ KURTH 1990, p. 33-35, pl. 10.

Stylistically, the Abydos fetish shows other interesting features: the two protective serpents on its bell-like upper part interestingly appear on the fetish from the small frieze on the ceiling, as we have proposed (fig. 43). This feature is absent in Bir el-Shaghala Tomb 2, the tomb of Petosiris at el-Muzawwaqa, Tuna el-Gebel, and Akhmim,¹⁷⁸ but only one serpent appears in the lower register on the north wall of the tomb of Petubastis in el-Muzawwaqa,¹⁷⁹ which may indicate a transitional phase in the life of this motif. These two serpents appear on a funerary bed in Berlin dated to the early Roman period, attributed to a Panopolite provenance,¹⁸⁰ an area with a strong link to Dakhla;¹⁸¹ however, the existence of the same motif on the Cleveland cartonnage recalls again the “Kharga Coffin Group”.¹⁸² It is worth noticing that this motif is found on cartonnages but not in tombs in the oases, so far as known, which links the painter to such workshops. The protective serpents for the Osirian fetish took many forms in the dynastic period: sometimes winged or lion-headed.¹⁸³ A canopic chest from the Asasif shows the two serpents pattern from the late fourth or early third centuries BC,¹⁸⁴ which could be a link between this Roman era composition and the dynastic period. Furthermore, it confirms the Theban influence on the funerary objects in the Great Oasis in Roman times.

The rest of the scenes on the four walls are damaged, and some reconstructions have already been proposed, but stylistically some elements are still comparable. First of all come the winged cobras on the west and east walls; the left side cobra on the eastern wall still preserves the whole composition, which finds a good parallel in the protective cobra on the Hathor-Aphrodite pronaos in the temple of Esna dedicated under Claudius.¹⁸⁵ The figure is comparable as well to a shroud in New York, perhaps from Thebes, dated to the 1st century BC.¹⁸⁶ The elongated head resting above the throat of the serpent and the tripartite division of the wings in both figures is close. A shroud in Boston from Akhmim, dated to the mid- or late first century CE, is rather similar, but here the execution is more schematic and the short tail rests on the *hbt*-sign. It would be better to compare the Bir el-Shaghala figure to the Kellis contra-temple plaster fragments with a winged cobra (fig. 32).¹⁸⁷ They are more elaborately painted and *iconic* in execution. The date of the contra-temple in Kellis is uncertain, but stylistically both depend on a common model, confirming the affinities between temple and tomb in the Roman period.

The figure of Wepwawet on the *shedshed*-emblem finds a typical parallel on a fragment of a funerary bed from el-Deir necropolis in Kharga Oasis.¹⁸⁸ The serpent motif is present as well, but very remarkable are the lines of the body, and the treatment of the almond-shaped eye with a black circle inside. These remarks lead the stylistic analysis into the mainstream of similarities

¹⁷⁸ The plaster paintings in the tombs at Akhmim are very damaged, and even by consulting the colored plates of KAPLAN 1999 and VENIT 2016, it seems that such serpents were not used. The fetish in House 21 in Tuna el-Gebel is protected by two ram-headed figures, VENIT 2016, fig. 4.9.

¹⁷⁹ OSING 1982, pl. 33c; VENIT 2016, p. 162, fig. 5.5.

¹⁸⁰ KURTH 2010, p. 121, fig. 16.

¹⁸¹ BAGNALL et al. 2015, pp. 335–349.

¹⁸² RIGGS 2005, pp. 73 ff, 283 no. 3, figs 13–15; TALLET 2014, p. 394, fig. 8.

¹⁸³ COULON 2011, pp. 85 ff, figs 7, 8, 10.

¹⁸⁴ BUDKA, MEKIS, BRUWIER 2013, pp. 209 ff, esp. 240, fig. 240.

¹⁸⁵ ABDELWAHED 2015, fig. 160.

¹⁸⁶ RIGGS 2008, p. 290 f, fig. 3.

¹⁸⁷ KAPER 1997a, p. 33, fig. 19.

¹⁸⁸ DUNAND 2012a, p. 435, pl. IX, 3.

between such funerary workshops and tomb painters in the Great Oasis, especially when a similar figure of Wepwawet from House 21 in Tuna el-Gebel is compared.¹⁸⁹ The eyes are less detailed and the rearing head of the serpent depends on a different stylistic concept.

The western wall with its classicized style is worthy of attention: its smaller scale, lighter bodies and the technique of shading by using double outlining indicate a different hand than the one that painted the south and north walls. The blue lotus and the vignette pattern in executing the scenes connect this painter to the Khargha cartonnage workshops, and likely the same hand finished the third and fourth registers on the eastern wall. This is apparent in the use of the same shading technique with two black and yellow lines on the wig of the seated figure in the third register (D17, fig. 30). The south wall shows an apparent iconographic influence of the “Kharga Coffin Group” as well: the Osirian fetish with two protecting serpents and the dotted *tjt*-signs; however, it is likely that a third painter worked on this part. The style of the Kharga atelier was characterized by concentric circles and double rendering of the nails. It is quite remarkable that the nails received particular care, as appears on the left foot of Nephthys on the west wall (figs 26, 27). This painter was perhaps itinerant or a coffin workshop artist active in Dakhla with strong affinities to Kharga workshops. However, these three artists seemingly belonged to an advanced phase of eclecticism in the Great Oases. Even the artist of the north wall, whose hand had the minimum amount of eclecticism, shows a revolutionary deviation from canonical Egyptian-style two-dimensional representations. He tried to finish the feet with natural perspective, not the rigid dynastic period conceptual style, exposing the two big toes to the viewer (figs 21, 22, 37, 45).

The figure of the deceased or mummified female Imsety in the apotheosis scene with an eye gazing upward is unique, and within tomb paintings no stylistic or iconographic parallel has been found. Its Egyptian forerunners are known in sculptures, and Bernard V. Bothmer

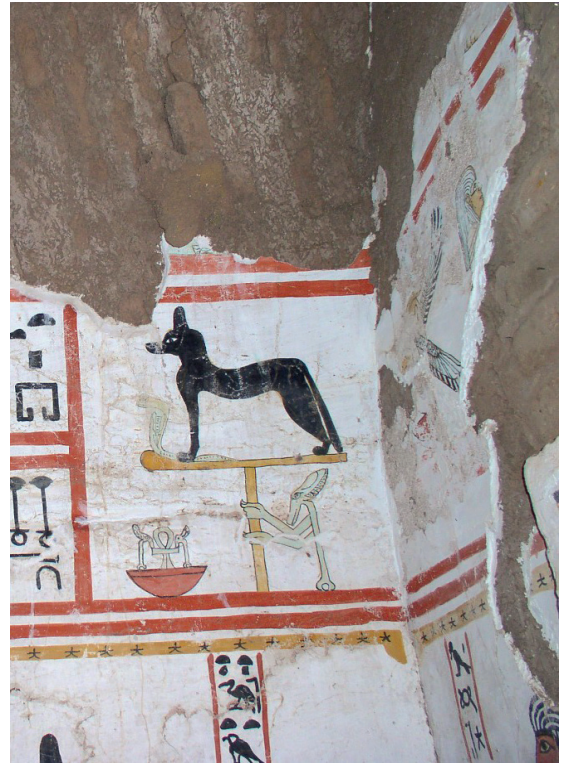

FIG. 45: Bir el-Shaghala, Tomb 1, ground floor, northern wall, third register: Wepwawet on a standard.



FIG. 46: A cartonnage fragment from Dabashiya (Kharga Storeroom Inv. No. 3591).

© Ministry of Tourism and Antiquities

¹⁸⁹ VENIT 2016, p. 123, fig. 4.15.

traced the attitude back to the 4th Dynasty,¹⁹⁰ with a concentration in sculptures in the later periods. The motif could move easily from sculpture to the eclectic style of the painter of the east and west walls, which has already been separated from other walls in the tomb. The painters of this room seemingly were very familiar with executing their subjects in similar small-scale shroud and cartonnage traditions, which is apparent in the vignettes that appear in successive snapshot-like scenes. The pattern of *b3*-birds within two border lines is perhaps owed to the lengthwise dividing lines or tiny friezes on mummy cartonnages and sarcophagi.

The *b3*-bird frieze on the ceiling pinpoints another stylistic comparison with the Kharga coffin workshops, glimpsed in a remarkable cartonnage fragment from Dabashiya¹⁹¹ (fig. 46). The cartonnage painter depicted two *b3*-birds on the chest whose color palette, proportion, mode of execution and style are strikingly similar to the *b3*-birds from Tomb 1 (figs 39, 40). It is difficult to imagine that the creators of these two figures worked separately or depended on a different model. This is clearer when compared to a bearded *b3*-bird on a wooden sarcophagus from Ain Labakha¹⁹² and another cartonnage fragment from Dabashiya¹⁹³ in Kharga in addition to *b3*-birds from el-Muzawwaqa tombs.¹⁹⁴ The Dabashiya cartonnage fragment is very significant evidence of the mobility of models and most probably artists, as attested within other material from both Dakhla and Kharga.¹⁹⁵ The *b3*-birds are depicted on some mummy cartonnages from Kellis,¹⁹⁶ although they are stylistically different in terms of colors, beard and modelling,¹⁹⁷ a feature that perhaps indicates that Mothis was a preferred destination for itinerant Kharga artists. However, it is possible that the Tomb 1 motif and the Dabashiya cartonnage, Inv. 3591 (fig. 46) were finished within a very close span of time, perhaps following a still-unknown model, which could be a similarly decorated tomb or a temple. Another significant example of similarity has been persuasively shown between paintings from Tuna el-Gebel House 21 and a group of cartonnages from Meir.¹⁹⁸

The Alexandrian iconographic and stylistic features in the paintings of this room are interesting; the damage to the offering table in the scene of the sons of Horus on the western wall is much regretted, since it reflects an Alexandrian influence; its floral decorative pattern appears only in the capital,¹⁹⁹ so far as known. The two feathers on the deceased head censing in front of Osiris follow the same style as the Kom el-Schugafa main tomb, but perhaps the pattern was developed in the Ptolemaic period as attested on the mummy cartonnage of Kerasher dated to the Augustan period.²⁰⁰ Likewise is the motif of winged cobras once appeared on a tombstone from Mafrusa in Alexandria, flanking *loti* and *atef* crowns²⁰¹, no doubt alluding to the Osirian faith, but standing as well as evidence of the mobility of motifs and concepts from the *chora* to Alexandria, not

¹⁹⁰ CODY 2004, pp. 250 ff. The same upraised head is known on canopic jars and stelae, see CODY 2004, p. 274.

¹⁹¹ DUNAND, IBRAHIM, LICHTENBERG 2012, p. 52, fig. 56.

¹⁹² IBRAHIM *et al.* 2008, fig. 261.

¹⁹³ DUNAND, IBRAHIM, LICHTENBERG 2012, p. 54, fig. 63c.

¹⁹⁴ VENIT 2016, pp. 158–183.

¹⁹⁵ DUNAND, IBRAHIM, LICHTENBERG 2012, pp. 21, 42.

¹⁹⁶ BIRRELL 1999, pp. 29–41, pl. 6; DUNAND, IBRAHIM, LICHTENBERG 2012, p. 44. n. 6.

¹⁹⁷ Our gratitude to Colin Hope for sharing some images of these cartonnage coffins (personal communication).

¹⁹⁸ RIGGS 2005, p. 132.

¹⁹⁹ VENIT 2016.

²⁰⁰ SEIPEL 1989, nos. 148–149.

²⁰¹ SCHMIDT 2003, Cat. 66.

the opposite. However, it outlines a central religious context for such popular Egyptian eclectic motifs in the capital. The few Alexandrian iconographic elements in addition to the horned altar and the *triclinium*-like rooms on the north side could be explained by the standard process of transferring the models from the center to the periphery. In the Dakhla context, the caravan metropoleis, like Thebes, Panopolis, Hermopolis and others, are very important contact points. Reasonable as well is a direct contact with Alexandria that could have been due to the conduct of official affairs; a significant case is known from the archive of the funerary workers (*nekrotaphoi*) from Kysis, showing such trips to the capital,²⁰² and perhaps the same for other ranks of officials. The *nekrotaphoi* are a very interesting link between the oases and Alexandria, and one may wonder how they spent their time off from their missions in the capital with its two enormous necropoleis or about their natural eagerness to contact their colleagues in the capital.

The architectural style of Tomb 1 places it earlier among the tombs of the pyramidal type in Bir el-Shaghala. It has an entrance with a torus of type E, which is used only in Roman times.²⁰³ The development of the pyramidal type in Bir el-Shaghala necropolis²⁰⁴ suggests a phase of activities in the necropolis between the first and third centuries CE. Tomb 1, in terms of architectural style, is the earliest in the necropolis, and finds a close parallel in the Amheida northern necropolis. Therefore it is datable to the first century CE. The style of the paintings suggests a date in the first half of the first century CE, since the connection with the Kharga atelier of coffins is apparent. The paintings show strong affinities to the tomb of Petosiris as well, and to a lesser degree to the tomb of Petubastis in el-Muzawwaqa. The tomb of Petubastis is dated to the first century CE,²⁰⁵ with the Osirian fetish showing a protective serpent being the only known example from Dakhla Oasis to date, and this rare feature perhaps puts these two tombs in a close chronological span. The *bz*-birds in Tomb 1, when compared to the Dabashiya cartonnage (fig. 46), may favor an earlier date than the second century, perhaps the late first century CE.

Another rare feature that is very helpful in dating the tomb is the figure of Tutu with a human body and lion's head. One other example is known from the temple of Kalabsha with an Augustan date,²⁰⁶ which may suggest a later date for this motif in the Dakhla Oasis. The Kellis mammisi as well presents a figure of Tutu with a human body and double-faced head, one human and one leonine,²⁰⁷ which is not exactly the same but closer in concept and chronology. The mammsi in Kellis is dated to the early 2nd century CE, and it seems reasonable that the one-headed Tutu predates the double-faced figure. Additional chronological evidence comes from Tomb 5, where a cow-headed goddess is depicted holding the tomb key, a feature that indicates the Trajanic age as *terminus post quem*.²⁰⁸ The stylistic affinities between the painters of Tombs 1 and 5 may suggest an earlier date for Tomb 1, perhaps later in the first century. If a narrower span of time for the *Ta-Dḥwtj* tomb is to be sought, it is likely to be the last quarter of that century.

202 BAGNALL et al. 2015, p. 304.

203 ABDELWAHED 2015, p. 135, fig. 147.

204 IBRAHIM, ASHOUR 2020.

205 OSING 1982, p. 71; WHITEHOUSE 1998, p. 262; VENIT 2016, p. 157 f.

206 KAPER 2003a, Doc. R 1, pp. 229–231.

207 KAPER 2009, p. 4, fig. on the unnumbered page.

208 GRIMM 1974, p. 117; KURTH 1990, pp. 1, 11.

5. THE SUBJECT AND FUNCTION OF THE DECORATION OF THE ANTECHAMBER

The scenes in the antechamber depict vignettes from the Egyptian *Book of the Dead* that are common in the Ptolemaic and Roman periods. The standard narration that ends in front of Osiris, depending on BD 125, uniquely begins with the *b3* of Re as a fully human figure, which insofar as known has no forerunner in Egyptian funerary representations. As a solar god, Re was involved in the resurrection, especially through his union with Osiris in the nocturnal journey of the deceased in the *Amduat*. This union is sometimes expressed in the formula “Re rests in Osiris and Osiris rests in Re”.²⁰⁹ A few illustrations are known in tombs from dynastic period where Re is depicted as a calf or more frequently as a ram-headed god.²¹⁰

This commanding presence of Re ensures that the *b3* of the deceased will to go into sky like the *b3* of Re,²¹¹ and interestingly indicates solar faith, which is in accordance with the pyramidal superstructure and its solar significance. The symbolic union of the two *b3*s of Osiris and Re on the nocturnal trip fits very well with the narration in the antechamber paintings, proposed to end with the resurrection and apotheosis of *Ta-Dḥwty*. The second attendant, Duamutef, leading the departed towards the balance deserves attention, not only because he replaces Anubis, but also because as a son of Horus his presence is required for the resurrection. The four sons of Horus were responsible for collecting the entrails of the deceased and reconstituting the body, as appears in the tomb of Petosiris at Tuna el-Gebel.²¹²

The same second register is crowded with pictorial and textual evidence of resurrection. First of all is the *djed*-pillar flanked by *tyt*-signs, symbolizing Isis and Nephthys praising Osiris. Isis here is labelled the divine mother of Osiris, who could be the resurrected deceased when she became Osiris NN. On the same wall the *b3*-bird appears twice, once labelled *b3 ntrw*, which raises the question of whether it is a later and freer interpretation of the *b3 dmd* of Osiris and Re from earlier times.²¹³ The Osirian hint in this epithet comes from the second line, reading “master of eternity”, which fits Osiris better than any other god, or at least a syncretised form of Osiris and Re.²¹⁴ The other *b3*-bird beside the niche has the caption *b3 ntr*, making Osiris the first candidate, although Re is possible as well, since both are involved in resurrection.

The third register is perhaps the peak of the narrative plot of resurrection; both west and east walls are accentuated by three border lines and winged cobras framing both scenes, messaging clear integration and uniformity. Furthermore, the fourth register on these two walls shows the solar barque in its night and day journeys, which confirms the same concept. The narration in the third register is better read from the west to the east wall. The third register on the west wall is better interpreted as two sons of Horus flanking and protecting an activity

²⁰⁹ ZABKAR 1968, pp. 36–39; SMITH 2017, pp. 302–305, 335–336.

²¹⁰ The union of the *b3* of Re and the *b3* of Osiris is depicted in the form of a ram-headed god in the tomb of Nefertari in the Valley of the Queens, and the scene is repeated in TT 335 and TT 336 from the Ramesside period, with the formula “Re rests in Osiris, Osiris rests in Re”. The same formula appears in TT 290 but a white calf is depicted between two trees; SMITH 2017, pp. 304–305.

²¹¹ SMITH 2017, p. 303.

²¹² BUDKA, MEKIS, BRUWIER 2013, pp. 241–243, figs 24, 25, 26; they are depicted on papyri as well.

²¹³ SMITH 2017, pp. 302–303, 335.

²¹⁴ SMITH 2017, pp. 302–336.

during the resurrection that included an offering table and standards, and perhaps an Osiride figure of the deceased in addition to a fourth attendant. The same pattern was perhaps used on the east wall: two sons of Horus, with only Imsety remaining; now missing are the figure of Hapy and a figure of the resurrected deceased, with at least a fourth missing attendant, as on the west wall. The figure gazing upwards on the east wall (D17) is depicted seated in mummified form, and its human face makes Imsety the most likely identification. Furthermore, the face depicted shows a prominent nose (fig. 30) very comparable to the nose of *Ta-Dḥwtj* (D2, fig. 22); therefore, identifying her as the same person is reasonable. Bothmer related this attitude of apotheosis to solar faith and the desire of Egyptians to see the shining sun,²¹⁵ a concept that accords well with the narration and iconography of these paintings. A figure of the sun god or one of his manifestations is much expected inside the day barque in the fourth register scene on the same eastern wall. It is remarkable that the two scenes are flanked by the winged Nekhbet and Wadjet, symbolizing Upper and Lower Egypt, which may be echoed in the presence of Busiris and Abydos on the north wall text (see Annex).

Resurrection could be contextualized by these two protective winged cobras as well, since such cobras mostly appear in connection with the *djed*-pillar,²¹⁶ which is a central concept in the rebirth of the deceased/Osiris.²¹⁷ At the Kellis contra-temple in Dakhla, winged cobras protecting a squatting figure inside a solar circle²¹⁸ are very significant and could represent the newly-born infant Re as Horus²¹⁹ (fig. 32). This solar symbolism is based on a doctrine very concerned with the role of Osiris-Re in the resurrection of the deceased.²²⁰ The connection of the four sons of Horus with resurrection is well documented as well; they are protectors of the sarcophagus of Osiris (BD 17) and they reconstitute the body of Osiris with whom each deceased person is assimilated.²²¹ In the Akhmim Von Bissing 1897 Tomb, they appear around the sarcophagus of Osiris, just beside a *djed*-pillar flanked by Isis and Nephthys.²²² It is noticeable that in the Akhmim tomb, when compared to earlier Egyptian representations of the sarcophagus of Osiris protected by the four sons of Horus,²²³ the human-headed figure could be either Osiris or the deceased assimilated to Osiris,

The offering table on the west wall is an important object; such tables appear constantly in the funerary scenes, especially those that narrate resurrection. The Teuris and Didyme sarcophagi are very comparable items. More interesting and mysterious is the oval object in this register (D22), which could be a lateral one among three objects placed together.²²⁴ This reconstruction explains why the mysterious object is not aligned to the center of the damaged

²¹⁵ CODY 2004, p. 275. Bothmer built his argument on the seated figures on raised bases seats, with heavenward gaze.

²¹⁶ NIELSEN 2000, figs 25–26; COULON 2011, pp. 85 ff, figs 7, 8, 10.

²¹⁷ A funerary stele in Turin, dated to Roman period, shows such winged cobras springing from a *djed*-pillar base, with the iconographic context indicating the resurrection of the deceased (Munro 1973, p. 264, fig. 77). A mummy cartonnage from Meir (RIGGS 2005, fig. 45), and on the wooden coffin of Didyme in el-Minia Museum (KURTH 1990, pl. 6).

²¹⁸ KAPER 1997a, fig. 19.

²¹⁹ SMITH 2017, p. 304. For a similar seated Harpokrates inside a sun disk with a resurrection context from the tomb of Siamun in Siwa, see VENIT 2016, p. 145, fig. 4.39.

²²⁰ ZABKAR 1968, pp. 36 ff.

²²¹ ALLEN 1974, p. 27, Spell 17, n. II; BUDKA, MEKIS, BRUWIER 2013, pp. 242–243.

²²² VENIT 2016, p. 186, fig. 5.29.

²²³ BUDKA, MEKIS, BRUWIER 2013, p. 242, fig. 26.

²²⁴ The crocodile tomb in Siwa (VENIT 2016, fig. 4.25), on funerary stelae (see MUNRO 1973, pl. 9, fig. 34), on a cartonnage from Dabashiya (see DUNAND, IBRAHIM, LICHTENBERG 2012, p. 52, fig. 56).

base on the ground line. Another possibility is that this oval object could be compared to an oval vessel on the Didyme sarcophagus, with a protecting serpent, reminiscent of the Osiris fetish.²²⁵ It could be reasonable to suggest an Osirian fetish in this scene, because it seems very connected to the concept of resurrection and to the apotheosis scene on the other wall. On the same sarcophagus there is an offering table with two stands, which may hint the original appearance of the two standards (D23) on the west wall. These remarks remain speculative since the scenes are much damaged and still lack a typical parallel.

The third register includes two other important items: an Osirian liturgy noticeably widespread in Dakhla tombs, such as the tombs of Kytinos, Petubastis and Petosiris. The liturgy emphasizes the *bj* of the dead and its liberty to fly as a bird out from and into the tomb.²²⁶ The significance of this concept is enhanced by the frieze of *bj*-birds and the Osirian fetish in the ceiling decoration (figs 39, 40, 41, 42). Remarkably, the *bj*-birds with open wings are painted green, a color that “was associated with fertility and vegetation, and thus with the concepts of renewal and fresh life”.²²⁷ The text, furthermore, alludes to the Khoiak festival of Sokar and the mysteries of the Osirian resurrection,²²⁸ and hence to the resurrection of the deceased: *Ta-Dḥwtj* in our context. The standards which flank these texts on both walls are noteworthy as well; the egg on the standard behind Thoht could signify many concepts, but at least in the Ramesside period the coffin was designated as the “egg”.²²⁹ An egg on a pilaster in the Tigrane tomb in Alexandria, even with its slightly different position and garland, may be recalled within a similar resurrection context.²³⁰ An egg in connection to the newly reborn sun is depicted on the ceiling of the tomb of Siamon in Siwa, notably above a *djed*-pillar flanked by Isis and Nephthys. The solar significance of the egg is well documented in the *Book of the Dead*.²³¹

The image of Wepwawet on a standard on the north wall is remarkable; his heading of processions is known in dynastic and later periods,²³² which may suggest a similar symbolism, perhaps in connection with the Sokar festival. The remains of another standard on the south wall suggest a fourth one on the north wall. In the tomb of Petosiris at el-Muzawwaqa, just above a similar text, there are figures of a falcon, an ibis and a jackal above a standard. Helen Whitehouse remarked on the connection between these three figures and the gods mentioned in the Osirian liturgy and their presence in the Osirian mysteries and the Khoiak Sokar festivals.²³³ It is possible that the text and figures in Tomb I third register embody the same concept, and give further support to the idea of resurrection.

The fourth register of the western wall further emphasizes the resurrection narrative; the solar boat, likely in the second hour, is very indicative. The counterpart on the eastern wall is likely to represent the solar barque in the daytime, denoting the resurrection of the deceased. These two paintings merge with the ceiling decorations with the frieze of *bj*-birds, which again

²²⁵ KURTH 1990, pp. 33-35, pl. 7.

²²⁶ WHITEHOUSE 1998, pp. 257-258.

²²⁷ SMITH 2017, p. 15.

²²⁸ ABDELWAHED 2015, pp. 306-307; WHITEHOUSE 1998, p. 258; VENIT 2016, pp. 158, 170.

²²⁹ SMITH 2017, p. 26, n. 98.

²³⁰ VENIT 2016, p. 80.

²³¹ Spell 17b; “O (Re) in his egg, shining in his Disk”, ALLEN 1974, p. 30 Si.

²³² Karnak Great Hypostyle Hall, within a royal procession leading Ramses II into the realm of Amun-Re; NELSON 1981 pl. 50; many scenes in the Hibis temple relating to the resurrection of Osiris, see DAVIES 1953, pl. 3, 4.

²³³ WHITEHOUSE 1998, p. 258; ABDELWAHED 2015, pp. 306-307; VENIT 2016, pp. 158, 170.

brings resurrection into the heart of the narrative. Tomb 1 has two burials, presumably of equal status, but likely *Ta-Dḥwtj* was the first buried, judging from her presence on the north wall and because of her name written on the ceiling of the interior room. The veneration of the Abydos fetish in the frieze of the *b3*-birds, with their elongated noses which recall the face of the deceased, is a remarkable realistic feature, however, it indicates the resurrection of Osiris or, in the Egyptian tradition, of the Osiris of *Ta-Dḥwtj*, the owner of the tomb. The presence of *ḥwt-dḥw* in the text within other Abydian affinities, especially the rite of tying on the crown of justification, is remarkable as well. This crown which is connected in Egyptian tradition to the Mansion-of-Provisions in Abydos (*ḥwt-dḥw*) and the cult of the Abydos fetish there, indicates the resurrection of the deceased as well.²³⁴

One interesting item was postponed until this point in the pictorial analysis: the rectangular niche by the end of the southern wall (fig. 29). Its depth of 44 cm and intact white plaster coating exclude the likelihood of oil lamps, unlike similar niches at Abusir el-Melegg.²³⁵ The well-known niche in Anfushy Tomb 2, with a lesser depth of only 30 cm,²³⁶ furnished with sockets to fix wooden shelves for funerary equipment, may suggest a different function for the Tomb 1 niche: perhaps to house a small statue. Other larger niches are known in the central room of Kellis South Tomb 4, with accentuated cultic function,²³⁷ which supports this conclusion. Around this niche are depicted the Osirian fetish, a *b3*-bird and Horus son of Isis, in addition to *the wd3t*-eye beneath its lower edge. This composition gives the niche more importance within the resurrection narrative, making it the focal point of a central ritual, perhaps with a statue inside. The proposed statue could be of Sokar-Osiris, in accordance with the Osirian liturgy on the north and south walls, but this statuary type is rare after the Ptolemaic period.²³⁸ Furthermore, if such a statue could be “an oasis tradition” deviating from the Nile valley traditions, it should be noted that Raven type D, with its six variations, with the majority of examples dated to the Ptolemaic period, includes 12 statues between 60–83 cm,²³⁹ making such an hypothesis very risky for a niche only 61 cm in height. The other possibility is an effigy of the deceased, made reasonable by the common Roman practice. Two private plaster portraits that were excavated from the neighboring Tomb 3²⁴⁰ are likely to come from a similar niche. Furthermore, the offering and renewal symbolism of the *wd3t*-eye²⁴¹ favors a statue or effigy of the deceased that was perhaps offered food and water on specific occasions.

The scene of the apotheosized deceased is very close to this niche, and her elevation to divine status was intended to secure her rejoicing and liberty of movement in the company of the deities, which corresponds to the Osirian liturgy on the north wall. It is worth considering whether or not such offerings were made during rituals performed in the antechamber venerating the deceased as a part of the funerary banquets performed in the *triclinium*-like rooms on the north side.

²³⁴ See COULON 2011, p. 105, and the Annex by the end of this article.

²³⁵ CARTRON 2012, II, p. 10, fig. 81.

²³⁶ ADRIANI 1952, pp. 68 ff; VENIT 2002, p. 80, fig. 64. The niche is 49 × 72 × 30 cm.

²³⁷ HOPE 2003, p. 283, fig. 25, pl. 71.

²³⁸ RAVEN 1978–1979, pp. 265–271; RIGGS 2005, p. 29.

²³⁹ RAVEN 1978–1979, p. 267, n. 118.

²⁴⁰ 2002–2003 excavation report, kept in Dakhla inspectorate.

²⁴¹ ASSMANN 2005, p. 357.

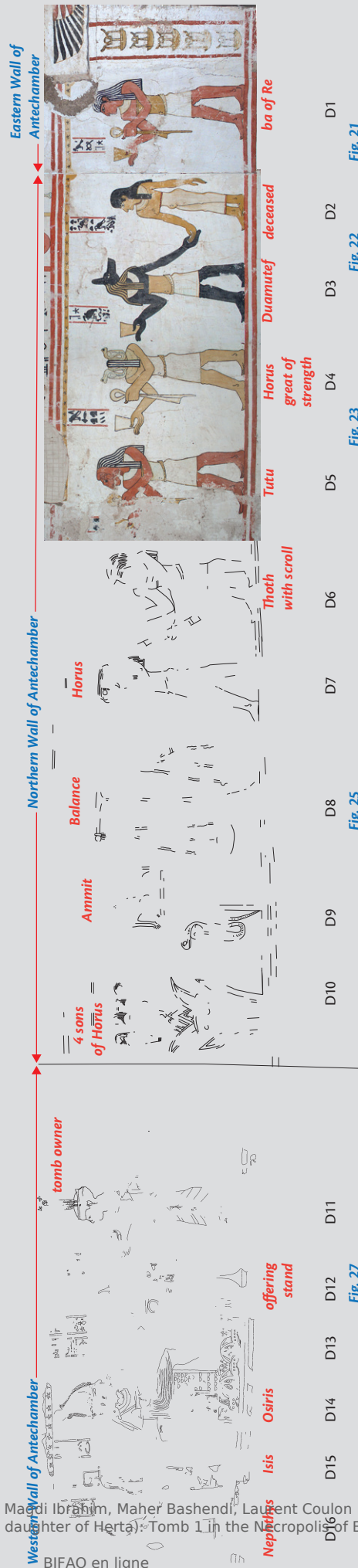

FIG. 47: Diagram of the figures on the Western, Northern and Eastern walls of the antechamber.

**ANNEX:
THE ‘DAKHLA OSIRIAN LITURGY’ IN TOMB I AT BIR EL-SHAGHALA**

LAURENT COULON²⁴²

In the third register of the south and north walls of the antechamber of Tomb I at Bir el-Shaghala, two lines of text can be identified as an Osirian liturgy well attested in Roman Dakhla tombs, such as the tomb of *Qtjnnws/Katenos*²⁴³ (Ezbet Bashendi),²⁴⁴ the tombs of Petosiris and Petubastis (Qaret el-Muzawwaqa),²⁴⁵ and the hitherto unpublished tomb of Petophois (*P3-dj-Wp-w3wt*) son of Pisechthis (*P3j-Stb*), also called Apollonios, at Bir el-Shaghala (no 5);²⁴⁶ textual allusions to this composition also occur on pieces of funerary equipment found in Ismant el-Kharab.²⁴⁷ Due to the unusual paleography of the hieroglyphs, typical of Roman period hieroglyphic inscriptions, and the unorthodox arrangement of the signs, the text is particularly difficult to decipher and the several parallels are hardly sufficient to reconstruct the original version. This preliminary study aims at improving the first translation of the text that was published by Jürgen Osing in 1982, based on the then available versions.

The version of Tomb I is only partially preserved. The upper part of the decoration of the antechamber has been much destroyed²⁴⁸ and a large part of the text, especially on the south wall, has disappeared. A few fragments of painted plaster that were collected during the excavations and gathered in wooden boxes will perhaps allow some future reconstructions.

On the south wall, only a few signs are still visible, at the end of the two lines. They can be identified as the end of the first sequences of the text (l. 1–2) (fig. 48). A fragment which probably belongs to this part of the decoration has been added in the photograph, but this will require verification *in situ*.

²⁴² Ifao/Ephe, PSL, AOROC, UMR 8546.

²⁴³ For this reading of the name, see BAGNALL et al. 2011, pp. 244–245 (26).

²⁴⁴ OSING 1982, pp. 63–66 and pl. 66, Text A, l. 2–3 and Text B; see also KURTH 1990, p. 27.

²⁴⁵ OSING 1982, pp. 80–81, pl. 70 and 92–94, pl. 71; see also KURTH 1990, p. 27; VENIT 2016, pp. 158 and 170.

²⁴⁶ I thank the co-authors of this article for providing me with photographs of this tomb. For the identity of the owner, see R. BAGNALL and G. VITTMANN in BAGNALL et al. 2015, pp. 335–343.

²⁴⁷ See O. KAPER, in HOPE 2003, p. 287; KAPER 2014, p. 360.

²⁴⁸ See *supra*.



Image editing by G. Pollin

FIG. 48: Tomb Nr. 1. Antechamber, South wall, 3rd register. End of lines 1 and 2 of the Osirian liturgy, with an additional fragment (see original photograph fig. 37).

The second part of the text (l. 3–4) is painted on the north wall; the end of the lines is not preserved (fig. 49).



Image editing by G. Pollin

FIG. 49: Tomb Nr. 1. Antechamber, North wall, 3rd register. Lines 3 and 4 of the Osirian liturgy.

Transliteration (of the preserved text)

[1] [... ...
 ...]jr b3.k sšm
 [2] [Skr...jr b3.k snsn m-hnw h]h [hryw-] [3] h3t (m)-hnw wsht m3^ctyw
 ts n.k m(3)h (m)-hnw hwt-df3w
 šm.k r m33? [...]n sn[.t? hn^c ntrw]
 [... ...] [4] 3ht sw 24 sšm Sk(r)-Wsjr sw 25
 pr b3.k (m-)hnw R(3)-s33w
 jr.k htpw hnk.k (n) nsw nbh n tpy 3ht sw 6(?)
 dj^c[3.k rd (m-)hnw Jmntt]

Translation

[1] [O Osiris NN, may you be great, strong and mighty! May you approach Osiris,²⁴⁹ may] your ba [2] guide [Sokar! May you pour water on the earth of Busiris and the nome of Abydos! May you enter into the sky with the gods that guide Sokar-Osiris, everyday! May you rejuvenate among the divine bas, may] your ba [breathe among the mil]lions of [fore][3]runners in the hall of the righteous^a.
 The crown is tied on for you in the Mansion of Provisions^b.
 May you go to see(?) [...] of the sixth [day(?)^c with the gods, may your tomb endure, your ba being on your corpse^d, may you enter the neshmet-bark of...] [4] on the 24th of Khoiak, guiding Sokar on the 25th. May your ba go forth from Ro-Setau^e!
 May you make offerings and present oblations to the king of eternity^e on the 6th(?) of Thot!
 [May you be given a position in the West!]^f

²⁴⁹ This incipit of the text is also painted in the central column of the vault of the western funerary chamber of Tomb 1. In the antechamber, the liturgy is (mistakenly) written with the second-person masculine pronoun (.k) instead of the feminine one (.t). This latter pronoun is correctly used in the incipit of the text on the ceiling of the western funerary chamber.

Commentary

a. The parallels read:

Tomb of *Qtjnnws/Katenos*, Text A:²⁵⁰ 

Tomb of *Qtjnnws/Katenos*, Text B:²⁵¹ 

Tomb of Petubastis (Qaret el-Muzawwaqa):²⁵² 

The parallel in Tomb 5 is partly damaged and provides no additional clue. The reading *hryw-h3t* “Vorfahren” has been suggested by D. Kurth,²⁵³ instead of J. Osing’s less convincing *mnjw-(r)-h3t / mnjw h3wtjw* “die, die früher / vorher verstorben sind / die früheren Verstobenen”. The spellings of *wsh t m3 tyw*²⁵⁴ differ considerably between versions; in our tomb, the sequence is barely recognizable.

b. The sequence was not understood by J. Osing, due to the unusual arrangement of signs and the barely recognizable form of the crown in the inscriptions of *Qtjnnws/Katenos*. The reading is nevertheless not doubtful.

Tomb of *Qtjnnws/Katenos*, Text A:²⁵⁵ 

Tomb of *Qtjnnws/Katenos*, Text B:²⁵⁶ 

The rite of “tying on the crown (of justification)”, through which Sokar-Osiris received the crown from Hornedjitef in Abydos during the feast of Wag, is well known.²⁵⁷ According to certain sources, this rite of “tying on the crown” was also performed on the 25th of Khoiak.²⁵⁸

The Mansion-of-Provisions (*hwt-df3w*) is a sacred place in Abydos.²⁵⁹ The connexion of the *hwt-df3w* with the crown of justification is clearly established in the papyrus of Nedjmet, where this rite is performed in the *j3t h3t df3w*, *h3t df3w* being an earlier variant of *hwt-df3w*: “The Prophet of Hornedjitef will go to the mound of the Mansion of Provisions (*j3t h3t df3w*)”

²⁵⁰ OSING 1982, pl. 66.

²⁵¹ OSING 1982, pl. 66.

²⁵² OSING 1982, pl. 70.

²⁵³ KURTH 1990, p. 27, n. 370 and p. 42.

²⁵⁴ For the *wsh t m3 tyw* instead of the more common *wsh t m3 ty* “Hall of the two truths”, see HERBIN 2008, p. 142 (line 12).

²⁵⁵ OSING 1982, pl. 66.

²⁵⁶ OSING 1982, pl. 66.

²⁵⁷ DERCHAIN 1955, pp. 234–237 ; see also HERBIN 1994, pp. 149–151 ; MEKIS 2012, pp. 251–252 (with ref.).

²⁵⁸ SMITH 2005, p. 221, Line 8 (d).

²⁵⁹ See recently TÖPFER 2015, pp. 132–133, n. [ax]); COULON 2018, pp. 695–697.

and come out bringing the crown of justification to Osiris foremost of the West.”²⁶⁰ This specific reference to the Abydene festivals is to be related to the important place given to them in the decoration of the Dakhla tombs.²⁶¹

- c. I cannot provide any satisfactory solution for the reading of this passage. The parallel in the tomb of *Qtjnnws/Katenos* reads:



Osing’s interpretation (*pr.k r [hrw] n tpyw [t3]*: “Wenn du herauskommst (zum Totenmahl) auf die Stimme der Lebenden hin”) has to be rejected as the number is 6 and not 7 (read *tp*), which is confirmed by the unpublished version in Tomb 5 at Bir el-Shaghala. A reading “*sn.t*”, “sixth day (festival)” could be suggested, as this lunar feast is often mentioned in funerary texts in connexion with offerings to the deceased,²⁶² but the whole sequence remains enigmatic. The presence of *hn’ ntrw* at the end of this sentence is confirmed by the version in Tomb 5.

- d. This reading relies on the versions of the tomb of *Qtjnnws/Katenos* at Ezbet Bashendi and Tomb no. 5 at Bir el-Shaghala.
- e. In the tomb of *Qtjnnws/Katenos*, the parallel reads:

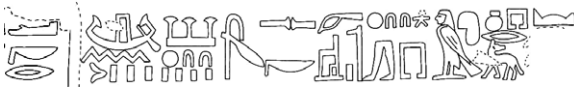

A reading ‘*q pr b3.k (m)-hmw R(3)-st3w* is also possible.

- f. In the tomb of *Qtjnnws/Katenos*, the parallel reads:



We follow the interpretation of J. Osing, his reading *tpy 3ht* being confirmed by our text. As for the day, the “6th” is possible, as well as the “3rd”. As the “king of eternity” is mentioned, to be identified with Osiris,²⁶³ this festival could be connected with the celebration of the eternity-*nbb* at the beginning of the year.²⁶⁴

²⁶⁰ Transl. after DERCHAIN 1965, p. 43.

²⁶¹ See for instance the representations of the Abydene fetish in OSING 1982, pl. 15a (*Qtjnnws/Katenos*); pl. 24c and 31c (*Petubastis*); *supra*, fig. 29 (Tomb 1). The procession of the fetish is shown in detail in another tomb at Bir el-Shaghala, see BASHENDI 2013, fig. 17-19; for the connexion between the *hwt-d3w* and the fetish, see COULON 2011, p. 105.

²⁶² See SMITH 2009, p. 701, *s.u.* “Sixth day festival”.

²⁶³ *LGG* IV, 330c-331c.

²⁶⁴ See HERBIN 1994, pp. 193 and 352.

As for the last sequence, *dj ʿ3.k rd (m)-ḥnw Jmntt*, the initial sign *dj* is clear in Tomb 1 at Bir el-Shaghala, so it can also be read this way in the tomb of *Qtjnnws/Katenos*.²⁶⁵

This spell addressed to the deceased is related by its content to the large corpus of Graeco-Roman funerary compositions, such as the “Liturgy of Opening the Mouth for Breathing” of papyrus Berlin 8351 or the “Book of Traversing Eternity”.²⁶⁶ Several themes extensively addressed in those texts are alluded to here in a concise manner: the journey of the deceased (and his *ba*) throughout the sky, earth and underworld, his participation in festivals in different sacred places, notably Busiris and Abydos, his freedom of movement, and his admission to the hierarchy of gods and blessed spirits. It should be noted that the deceased is here the one making the offerings instead of being the beneficiary.

BIBLIOGRAPHY

ABDELWAHED 2015

Abdelwahed, Y., *Egyptian Cultural Identity in the Architecture of Roman Egypt (30 BC-AD 325)*, Oxford, 2015.

ADRIANI 1952

Adriani, A., *Annuaire du Musée Gréco-Romain, 1940-50*, Alexandria, 1952.

ADRIANI 1966

Adriani, A., *Repertorio d'arte dell'Egitto greco-romano. Serie C, Architettura*, Palermo, 1966.

ALLEN 1974

Allen, T.G., *The Book of the Dead or Going Forth by Day: Ideas of the Ancient Egyptians Concerning the Hereafter as Expressed in their Own Terms*, SAOC 37, Chicago, 1974.

ARNOLD 1999

Arnold, D., *Temples of the Last Pharaohs*, Oxford, 1999.

ASSMANN 2005

Assmann, J., *Death and Salvation in Ancient Egypt*, D. Lorton (trans.), London, 2005.

AUBERT 2008

Aubert, M-F, *Portraits funéraires de l'Égypte romaine: cartonnages, lincoils et bois*, Paris, 2008.

BADAWY 1957

Badawy, A., “A Sepulchral Chapel of Greco-Roman Times at Kom Abu Billo (Western Delta)”, *JNES* 16, 1957, pp. 52–54.

BAGNALL et al. 2011

Bagnall, R.S. Worp, K.A., Hope, C.A., “Family Papers from Second-Century A.D. Kellis”, *CdE* 86/171-172, 2011, pp. 228–253.

BAGNALL et al. 2015

Bagnall, R., R., Vittmann, G., Criboire, R., “Inscriptions from Tombs at Bir esh-Shaghala”, *CdE* 90, 2015, pp. 335–349.

BASHENDI 2013

Bashendi, M., “A Roman Period Tomb with a Pyramidal Superstructure in Bir el-Shaghala (Mut, Dakhla Oasis)”, *BIFAO* 113, 2013, pp. 51–79.

BERMAN, BOHAČ 1999

Berman, L., Boháč, K. (eds.), *Catalogue of Egyptian Art*. The Cleveland Museum of Art, New York, 1999.

BIRRELL 1999

Birrell, M. “Excavations in the cemeteries of Ismant el-Kharab”, in C.A. Hope, A.J. Mills (eds), *Dakhleh Oasis Project: Preliminary Reports on the 1992–1993 and 1993–1994 Field Seasons*, Oxford, 1999, pp. 29–41.

²⁶⁵ See the similar sentences quoted by SMITH 1993, pp. 51–52, l. 6 (c).

²⁶⁶ See SMITH 2009, esp. pp. 349–366 and 395–431.

- BIRRELL 2000
 Birrell M., "Portcullis Stones: Tomb Security during the Early Dynastic Period", *BACE* 11, 2000, pp. 17–28.
- BRUYÈRE 1925
 Bruyère, B., *Rapport sur les fouilles de Deir el Médineh (1923-1924)*, FIFAO 2, Cairo, 1925.
- BRUYÈRE 1929
 Bruyère B., *Rapport sur les fouilles de Deir el Médineh (1928)*, FIFAO 6, Cairo, 1929.
- BUDGE 1913
 Budge, W., *The Greenfield papyrus in the British Museum: The funerary papyrus of princess Nesitanebtashru, daughter of Painetchem II and Nesi-Khensu, and priestess of Amen-Rā at Thebes, about B. C. 970*, London, 1913.
- BUDKA et al. 2013
 Budka, J., Mekis, T., Bruwier, M.-C., "Reuse of Saïte Temple Tombs in the Asasif during the Early Ptolemaic Time – The Tomb Group of *Mw.t-Mnw* from TT 414", *ÄgLev* 22/23, 2013, pp. 209–251.
- CARTRON 2012
 Cartron, G., *L'architecture et les pratiques funéraires dans l'Égypte romaine*, 2 vol., BAR-IS 2398, Oxford, 2012.
- CLÉDAT 1909
 Clédat, J., "Recherches et fouilles au Mont Casios et au lac Sirbonis", *CRAIBL* 53, 1909, pp. 764–774.
- CODY 2004
 Cody, M., *Egyptian Art: Selected Writings of Bernard V. Bothmer*, Oxford, 2004.
- CORBELLI 2006
 Corbelli, J.A., *The Art of Death in Graeco-Roman Egypt*, *ShirEgypt* 28, Aylesbury, 2006.
- CORCORAN 1995
 Corcoran, H., *Portrait Mummies from Roman Egypt (I-IV Centuries A.D.)*, SAOC 56, Chicago.
- COULON 2011
 Coulon, L., "Un motif osirien et sa diffusion à l'époque saïte", in D. Devauchelle (ed.), *La XXVI^e dynastie, continuités et ruptures. Promenade saïte avec Jean Yoyotte, Actes du Colloque international organisé les 26 et 27 novembre 2004 à l'université Charles-de-Gaulle – Lille 3*, Paris, 2011, pp. 85–108.
- COULON 2018
 Coulon, L., "Entre Bousiris et Abydos, la (dé)rive de Nédit : mythologie égyptienne et dualisme géographique", in L. Medini, G. Tallet (eds), *Qu'est-ce qu'un mythe égyptien ? – 10^e Table ronde de l'Atelier Aigyptos, Revue de l'Histoire des Religions* 235, 2018, pp. 683–699.
- DARESSY 1902
 Daressy, G., "Tombeau ptolémaïque à Atfieh", *ASAE* 3, 1902, pp. 160–182.
- DAVIES 1953
 Davies, N. de G., *The Temple of Hibis in El Khārgēh oasis, Part III: The Decoration*, MMAEE 17, New York, 1953.
- DERCHAIN 1955
 Derchain, P., "La couronne de la justification. Essai d'analyse d'un rite ptolémaïque", *CdE* 30, 1955, pp. 225–287.
- DERCHAIN 1965
 Derchain, P., *Le Papyrus Salt 825, rituel pour la conservation de la vie en Égypte (B.M. 10051)*, Brussels, 1965.
- DERRIKS, DELVAUX 2009
 Derriks, C., Delvaux, L., *Antiquités égyptiennes au Musée royal de Mariémont*, Morlanwelz, 2009.
- DUNAND 2012
 Dunand, F., "Anubis, Oupouaout et les autres", in C. Zivie-Coche, I. Guermeur, J. Yoyotte, « *Parcourir l'éternité* », *BEHE* 156, Turnhout, 2012, pp. 427–439.
- DUNAND, HEIM, LICHTENBERG 2012
 Dunand, F., Heim, J.-L., Lichtenberg, R. (dir.), *El-Deir Nécropoles, II. Les nécropoles Nord et Nord-Est*, Paris, 2012.
- DUNAND, IBRAHIM, LICHTENBERG 2012
 Dunand, F., Ibrahim, B., Lichtenberg, R., *Le matériel archéologique et les restes humains de la nécropole de Dabashiya (Oasis de Kharga)*, *CENiM* 7, Montpellier, 2012.
- DUNHAM 1972
 Dunham, D., *Recollections of an Egyptologist*, Museum of Fine Arts, Boston, 1972.

- EDGAR 1903
Edgar, C.C., *Greek sculpture*, CGC 27525-27630, Cairo, 1903.
- EIGNER 1984
Eigner, D., *Die monumentalen Grabbauten der Spätzeit in der thebanischen Nekropole*, UZK 8, Vienna, 1984.
- FISCHER 1963
Fischer, H.G., *Varia Aegyptiaca*, *JARCE* 2, 1963, pp. 15–51.
- GABRA 1941
Gabra, S., *Rapport sur les fouilles d'Hermoupolis Ouest (Touna el-Gebel)*, Cairo, 1941.
- GABRA 1971
Gabra, S., *Chez les derniers adorateurs du Trismegiste: la nécropole d'Hermopolis, Touna el Gebel. (Souvenir d'un Archéologue)*, Cairo, 1971.
- GERMER 1997
Germer, R., *Das Geheimnis der Mumien: Ewiges Leben am Nil. Ausstellung, Museum für Kunst und Gewerbe Hamburg, 24.1–20.4.1997*, Munich, New York, 1997.
- GRIMM 1974
Grimm, G., *Die römischen Mumienmasken aus Ägypten*, Wiesbaden, 1974.
- GUIMIER-SORBETS et al. 2017
Guimier-Sorbets, A.M., Pelle, A., Seif el-Din, M., Empereur, J.-Y., Clement, C., *Resurrection in Alexandria: The Painted Greco-Roman Tombs of Kom al-Shuqafa*, Cairo, 2017.
- HERBIN 1994
Herbin, F.-R., *Le Livre de Parcourir l'Éternité*, OLA 58, Leuven.
- HERBIN 2008
Herbin, F.-R., “Trois papyrus hiéroglyphiques d'époque romaine”, *RdE* 59, 2008, pp. 125–154.
- HOPE 2003
Hope, C.A., “The Excavations at Ismant el Kharab from 2000 to 2002”, in G.E. Bowen, C.A. Hope (eds.), *The Oasis Papers 3: Proceedings of the Third International Conference of the Dakhleh Oasis Project*, Oxford, pp. 207–289.
- HOPE, MCKENZIE 1999
Hope, C.A., McKenzie, J., “Interim Report on the West Tombs”, in C.A. Hope, A.J. Mills (eds.), *Dakhleh Oasis Project: Preliminary Reports on the 1992–1993 and 1993–1994 Field Seasons*, Oxford, pp. 53–68.
- HOPE 2014
Hope, C.A., “The Kellis 1 Cemetery: Roman Period Burial Practices in Dakhleh Oasis”, in G. Tallet, C. Zivie-Coche (eds.), *Le myrte et la rose*, *CENiM* 9, Montpellier, 2014, pp. 325–48.
- HOPE et al. 2009
Hope, C.A., Bowen, G.E., Cox, J., Dolling, W., “Report on the 2009 Season of Excavations at Mut El-Kharab, Dakhleh Oasis”, *BACE* 20, 2009, pp. 47–86.
- HORNUNG 1999
Hornung, E., *Das Grab Sethos' I*, Zürich, 1999.
- IBRAHIM, ASHOUR 2020
Ibrahim, M., Ashour, S., “The Bir el-Shaghala Necropolis: an Architectural Overview”, in C. Hope, G. Bowen (eds.) *Proceedings of the Ninth International Dakhleh Oasis Project Conference: Papers presented in honour of Anthony J. Mills (Dakhleh Oasis Papers 9)*, Oxford, 2020, pp. 167–213.
- IBRAHIM et al. 2008
Ibrahim, B.A., Dunand, F., Heim, J.-L., Hussein, M., Lichtenberg R., *Le matériel archéologique et les restes humains de la nécropole d'Aïn el-Labakha, oasis de Kharga*, Paris, 2008.
- KAMPP 1996
Kampp, F., *Die Thebanische Nekropole. Zum Wandel des Grabgedankens von der XVIII. bis zur XX. Dynastie*, Theben 13, Mainz am Rhein, 1996.
- KAPER 1997a
Kaper, O., *Temples and Gods in Roman Dakhleh, Studies in the indigenous cults of an Egyptian oasis*, PhD Thesis, Rijksuniversiteit Groningen, 1997.
- KAPER 1997b
Kaper, O., “A Painting of the Gods of Dakhla in the Temple of Ismant el-Kharab”, in S. Quirke (ed.), *The Temple in Ancient Egypt: New Discoveries and Recent Research*, London, pp. 204–215.

- KAPER 2001
Kaper, O., "Two Decorated Blocks from the Temple of Seth in Mut el-Kharab", *BACE* 12, 2001, pp. 71–78.
- KAPER 2003a
Kaper, O.E., *The Egyptian God Tutu. A Study of the Sphinx-God and Master of Demons with a Corpus of Monuments*, OLA 119, Leuven, 2003.
- KAPER 2003b
Kaper, O., "The Decoration of North Tomb 1", in G.E. Bowen, C.A. Hope (eds), *The Oasis Papers 3: Proceedings of the Third International Conference of the Dakhleh Oasis Project*, Oxford, pp. 323–330.
- KAPER 2009
Kaper, O., "Restoring Wall Paintings of the Temple of Tutu", *EgArch* 35, 2009, pp. 3–7.
- KAPER 2014
Kaper, O., "Coffin or Bed? Decorated Biers from Hellenistic and Roman Egypt", in G. Tallet, C. Zivie-Coche (eds), *Le myrte et la rose. Mélanges offerts à Françoise Dunand par ses élèves, collègues et amis*, CENiM 9, Montpellier, 2014, pp. 357–370.
- KAPER 2015
Kaper, O., "Funerary Life: The pyramids", in R.S. Bagnall, N. Aravecchia, R. Cribiore, P. Davoli, O.E. Kaper, S. McFadden, *An Oasis City*, New York, pp. 170–6.
- KAPLAN 1999
Kaplan, I., *Grabmalerei und Grabreliefs der Römerzeit: Wechselwirkung zwischen der ägyptischen und griechische-alexandrinischen Kunst*, Wien, 1999.
- KEMP 1975
Kemp, B., *LÄ* I, 1975, cols. 28–42, s.v. "Abydos".
- KESSLER, BROSE 2008
Kessler, D., Brose P., *Ägyptens letzte Pyramide: Das Grab des Seuta(s) in Tuna el-Gebel*, Haar, 2008.
- KURTH 1990
Kurth, D., *Der Sarg der Teüris. Eine Studie zum Toten glauben im römerzeitlichen Ägypten*, AegTrev 6, Mainz am Rhein, 1990.
- KURTH 2010
Kurth, D., *Materialien zum Toten glauben im römerzeitlichen Ägypten*, Hützel, 2010.
- LANDVATTER 2013
Landvatter, T., "Burial Practices and Rituals Landscape at Ptolemaic Abydos: The 2011 and 2012 Seasons of the Abydos Middle Cemetery Project", *NEA (ASOR)* 76, 2013, pp. 235–245.
- MARIETTE 1880
Mariette, A., *Abydos : description des fouilles exécutées sur l'emplacement de cette ville. Temple de Sêti (Supplément)-Temple de Ramsès-Temple d'Osiris-Petit temple de l'ouest-Nécropole*, Paris, 1880.
- MARTIN 1977
Martin, T.G., "Excavations at the Memphite Tomb of Horemheb, 1976: Preliminary Report", *JEA* 63, 1977, pp. 13–19.
- MARTIN 1982
Martin, T.G., "The Tomb of Tia and Tia: Preliminary Report on the Saqqâra Excavations, 1983", *JEA* 70, 1984, pp. 5–12.
- MEKIS 2012
Mekis, T., "The Cartonnage of Nestanetjereten (Louvre AF 12859; MG E 1082) and its Enigma", *BIFAO* 112, 2012, pp. 243–274.
- MILLS 1980
Mills, A.J., 1980, "The Dakhleh Oasis Project. Report on the Second Season of Survey. September–December, 1979", *JSSEA* 10, 1980, pp. 251–282.
- MONTERRAT 1992
Montserrat, D., "The « Kline » of Anubis", *JEA* 78, 1992, pp. 301–307.
- MOSTAFA 1989
Mostafa, D., "Remarks on New Kingdom Private Tombs with Pyramidal Shaped Superstructures", *JFA (C)* 3, 1989, pp. 114–125.
- MUNRO 1973
Munro, P., *Die spätägyptischen Totenstelen*, ÄgForsch 25, Glückstadt, 1973.
- NELSON 1981
Nelsen, H.H., *The Great Hypostyle Hall at Karnak*. Vol. 1, Part I: *The Wall Reliefs*, OIP 106, Chicago, Illinois.

- NENNA 2018
Nenna, M.-D., “Archaeology of the Funerary Cult in Hellenistic and Roman Aleandria: Architectural and Material Arrangements”, in M.-D. Nenna, S. Huber, W. Van Andringa (eds), *Constituer la tombe: honorer les défunts en Méditerranée antique*, *EtudAlex* 46, Alexandria, 2018, pp. 65–115.
- NIELSEN 2000
Nielsen A. M, *Guide to the collections Ny Carlsberg Glyptotek*, Copenhagen, 2000.
- NIWINSKI 1989
Niwinski, A., *Studies on the Illustrated Theban Funerary Papyri of the 11th and 10th Centuries B.C.*, OBO 86, Freiburg, 1989.
- OSING 1982
Osing, J., *Denkmaler Oase Dakhla, Aus Dem Nachlass Von Ahmed Fakhry*, *ArchVer* 28, Mainz am Rhein, 1982
- PADRÓ 2007
Padró, J., “Recent Archaeological Work”, in A.K. Bowman, R.A. Coles, N. Gonis, D. Obbink, P.J. Parsons (eds), *Oxyrhynchus: A City and its Texts*, GRM (L) 93, London, pp. 129–138.
- PARLASCA, SEEMAN 1999
Parlasca, K., Seeman, H., *Augenblicke, Mummenporträts und Ägyptische Grabkunst Aus Römische zeit*, Frankfurt, 1999.
- PASCUAL 2008
Pascual, E. S., *La maison funéraire de la nécropole haute à Oxyrhynchos (el Minyâ, Égypte) du tombeau à la diaconie*, *Oxyrhynchos II*, *NSAeg* 5, Barcelona, 2008.
- PECK 1972
Peck, W.H., “A Ramesside Ruler Offers Incense”, *JNES* 31, 1972, pp. 11–15.
- PEET 1914
Peet, T.E., *The Cemeteries of Abydos II*, *EEF* 33, London, 1914.
- PETRIE 1911
Petrie, F., *Roman Portraits and Memphis (IV)*, London, 1911.
- PIANKOFF 1958
Piankoff, A., “Les Peintures dans la Tombe du roi Ai”, in *Festschrift zum 80. Geburtstag von Professor Dr. Hermann Junker*, II, *MDAIK* 16, 1958, pp. 247–251.
- RAVEN 1978-1979
Raven, M., “Papyrus-Sheaths and Ptah-Sokar-Osiris Statues”, *OMRO* 59–60, 1978–1979, pp. 251–296.
- REDDÉ 1992
Reddé, M., *Douch IV. Le trésor : inventaire des objets et essai d'interprétation*, *DFIFAO* 28, Cairo, 1992.
- RIGGS 2005
Riggs, C., *The Beautiful Burials of Roman Egypt*, *Oxford Studies in Ancient Culture and Representation*, Oxford, 2005.
- RIGGS 2008
Riggs, C., “Gilding the Lily: Sceptres and Shrouds in Greco-Roman Egypt”, in S.E. Thompson, P. Der Manuelian (ed.), *Egypt and Beyond: Essays Presented to Leonard H. Lesko upon his Retirement from the Wilbour Chair of Egyptology at Brown University June 2005*, Providence (RI), 2008, pp. 290–291.
- RONDOT 2004
Rondot, V., *Tebtynis II. Le Temple de Soknebtynis et son dromos. Fouilles franco-italiennes 2*, *FIFAO* 50, Cairo, 2004.
- SALEH 1996
Saleh, M., *Cairo, the Egyptian Museum and Pharaonic sites*, Cairo, 1996.
- SCHMIDT 2003
Schmidt, S., *Grabreliefs in Griechische-römische museum von Alexandria*, *ADAIK* 17, Cairo, 2003.
- SCHREIBER 1908
Schreiber, T., *Die Nekropolis von Kôm-esch-Schukâfa (Expedition Ernst von Sieglin ausgrabung in Alexandria I)*, Leipzig, 1908.
- SEEBER 1976
Seeber C., *Untersuchungen zur Darstellung des Totengerichts im Alten Ägypten*, *MÄS* 35, Munich, 1976.

- SEIPEL 1989
Seipel, W., *Ägypten: Götter, Gräber und die Kunst, 4000 Jahre Jenseitsglaube. Katalog zur Ausstellung Ägypten, Götter und die Kunst – 4000 Jahre Jenseitsglaube, Schloßmuseum Linz, 9. April bis 28. September 1989*, Linz, 1989.
- SMITH 1993
Smith, M., *The Liturgy of Opening the Mouth for Breathing*, Oxford, 1993.
- SMITH 2005
Smith, M., *Papyrus Harkness (MMA 31.9.7)*, Oxford, 2005.
- SMITH 2009
Smith, M., *Traversing Eternity. Texts for the Afterlife from Ptolemaic and Roman Egypt*, Oxford, 2009.
- SMITH 2017
Smith, M., *Following Osiris: Perspectives on the Osirian Afterlife from Four Millennia*, Oxford, 2017.
- TALLET 2014
Tallet, G., “Fragments d’el-Deir (Oasis de Kharga) au tournant de notre ère. À propos de Carl Schmidt et de William Hornblower”, in *Le myrte et la rose. Mélanges offerts à Françoise Dunand par ses élèves, collègues et amis*, CENiM 9, Montpellier, 2014, pp. 394–398.
- TARASENKO 2012
Tarasenko, M., The Vignettes of the Book of the Dead Chapter 17 during the Third Intermediate Period (21st –22nd Dynasties), *SAK* 41, 2012, pp. 379–394
- TÖPFER 2015
Töpfer, S., *Das Balsamierungsritual. Eine (Neu-) Edition der Textkomposition Balsamierungsritual (pBoulaq 3, pLouvre 5158, pDurham 1983.II + pSt. Petersburg 18128)*, SSR 13, Wiesbaden, 2015.
- VENIT 2002
Venit, M. S., *Momumental Tombs of Alexandria, The Theatre of the Dead*, Cambridge, 2002.
- VENIT 2016
Venit, M.S., *Visualizing the Afterlife in the Tombs of Graeco-Roman Egypt*, Cambridge, 2016.
- WALKER, BIERBIER 1997
Walker, S., Berbrier, J., *Ancient Faces, Mummy portraits from Roman Egypt. Exhibition, the British Museum, 1997*, London, 1997.
- WARNER 2004-2005
Warner, N., “Architectural Conservation”, in A.J. Mills, *Dakkeh Oasis Project, Report to the Supreme Council of Antiquities on the 2004-2005 Field Season*, <https://www.monash.edu/_data/assets/pdf_file/0020/2013617/dakkeh-report-2004-2005.pdf>, accessed 17 June 2020.
- WHITEHOUSE 1998
Whitehouse, H., “Roman in Life, Egyptian in Death: The Painted Tomb of Petosiris”, in *Life on the Fringe: Living in the Southern Egyptian Deserts during the Roman and Early-Byzantine Periods. Proceedings of a Colloquium Held on the Occasion of the 25th Anniversary of the Netherlands Institute for Archaeology and Arabic Studies in Cairo, 9-12 December 1996*, Leiden, 1998, pp. 253–270.
- WINLOCK 1914
Winlock, H. E., “Excavations at Thebes in 1912-13, by the Museum’s Egyptian Expedition”, *BMMA* 9/1, 1914, pp. 11–23.
- WINLOCK 1936
Winlock, H.E., *Ed Dakhleh Oasis: Journal of a Camel Trip Made in 1908*, New York, 1936.
- YAMANI 2001
Yamani, S., “Roman Monumental Tombs in Ezbet Bashendi”, *BIFAO* 101, 2001, pp. 393–414.
- YAMANI forthcoming
Yamani, S. *Cemeteries of Late Periods in Dakhla Oasis* (forthcoming).
- ZABKAR 1968
Zabkar, L.V., *A Study of the Ba Concept in Ancient Egyptian Texts*, SAOC 34, Chicago, 1968.
- ZOAIR et al. 2018
Zoair, N., Omran, W., Abd el-Nasser, G., Abou Gabal, A., “La tombe F2 de la nécropole d’Al-Salamuni à Akhmim”, in M.-D. Nenna, S. Huber, W. Van Andringa (eds), *Constituer la tombe : honorer les défunts en Méditerranée antique*, EtudAlex 46, Alexandria, 2018, pp. 163–198.